

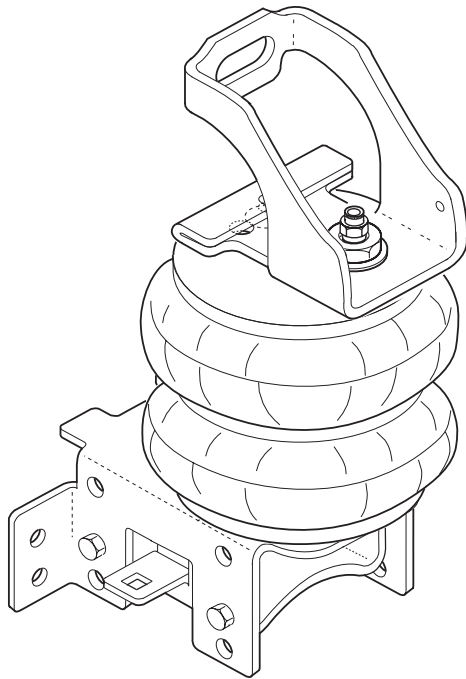

riderite.com

# INSTALLATION INSTRUCTIONS



**SECTION 1 - AIR SPRING**

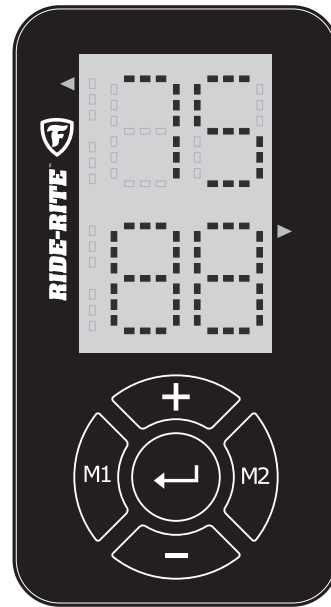

**SECTION 2 - AIR ACCESSORY**

# Firestone

Firestone Industrial Products

# ! IMPORTANT

PLEASE DON'T HURT YOURSELF, YOUR KIT OR YOUR VEHICLE. TAKE A MINUTE TO READ THIS IMPORTANT INFORMATION.

**DO NOT INSTALL IF THE TRUCK HAS BEEN LIFTED AND THE STOCK JOUNCE BUMPER SPACERS ARE NOT ON THE VEHICLE.** *This kit is to be used on a pickup truck only, and DOES NOT INCREASE YOUR VEHICLE'S MAXIMUM LOAD.*

## **SAFE INSTALLATION**

Please take all safety precautions during installation. A hydraulic jack can fail, and if that happens, you can be seriously hurt, or worse, if you are relying on it to hold up the vehicle. If you use a hydraulic jack, secure jack stands in the appropriate locations and chock any tires still touching the ground.

Wear safety glasses or goggles. Your eyes may be lower than some parts and pieces, and you don't want to lose an eye.

Remove the possibility of any electrical issues by disconnecting the negative battery cable.

## **KIT CLEARANCE**

There must be a minimum of 1/2" clearance around all installed components when the Air Springs are inflated and under a load. The Air Springs must flex and expand during operation, so the clearance keeps the kit from rubbing against parts of the vehicle.

## **VEHICLE GVWR**

NEVER exceed the maximum load recommended by the vehicle manufacturer (GVWR). The GVWR can be found in your vehicle's owner's manual or on the data plate on the driver's side door. Consult your local dealership for additional GVWR specifications.

## **INFLATING THE AIR SPRINGS**

When inflating Air Springs, add air pressure in small quantities, checking air pressure frequently. The Air Springs have much less air volume than a tire, so they inflate much more quickly.

## **PRESSURE TO LOAD**

The Air Springs will support approximately 50 lbs. of load for each PSI of inflation pressure (per pair). For example, 50 PSI of inflation pressure will support a load of 2500 lbs. per pair of Air Springs.

## **APPROPRIATE AIR PRESSURE**

For best ride, use only enough air pressure in the Air Springs to level the vehicle when viewed from the side (front to rear). This will vary, depending on the load, location of the load, condition of the existing suspension, and personal preference.

## **OPTIONAL T-FITTING**

This kit includes Inflation Valves and Air Line Tube for each Air Spring, allowing you to compensate for unbalanced loads. If you prefer a single Inflation Valve system to provide equal pressure to both Air Springs, your dealer can supply the optional "T" fitting (Part # 3025 or WRI-760-3461 retail pack).

**ONCE INSTALLED SUCCESSFULLY, FOLLOW THESE PRESSURE REQUIREMENTS FOR THE AIR SPRINGS:**

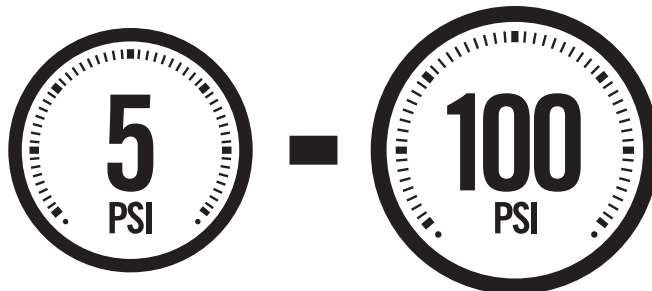







MINIMUM PRESSURE

MAXIMUM PRESSURE (LOADED)

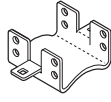
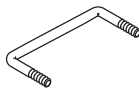

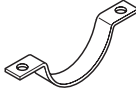
# SECTION 1 PARTS

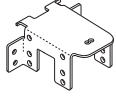
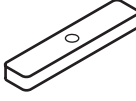
Compare the parts below to your kit. Assure you have all pieces, and organize them for an easier installation.















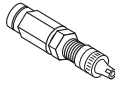





## AIR SPRING CONTENTS

PT # 6401	 x2 AIR SPRING	PT # 5379	 x2 SADDLE BRACKET	PT # 3077	 x2 BAIL CLAMP
PT # 5572	 x2 UPPER BRACKET	PT # 1163	 x2 AXLE STRAP BRACKET	PT # 1004	 x1 HEAT SHIELD
PT # 5380	 x2 LOWER BRACKET	PT # 5477	 x2 1/2" SPACER	PT # 9415	 x1 AIR LINE TUBE (22 FEET)

## A24-760-7560 INFLATION VALVE BRACKET KIT

PT # 9483	 x1 NO-DRILL INFLATION VALVE BRACKET	PT # 9488	 x2 LARGE NYLON TIE
-----------	---	-----------	---

## A21-760-2550 HARDWARE PACK

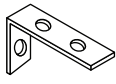
PT # 0065	 x1 5/16" - 24 x 3/4" HEX HEAD BOLT	PT # 3067	 x18 3/8" - 16 FLANGE LOCK NUT	PT # 3296	 x2 3/4" LOCK WASHER
PT # 3056	 x1 5/16" - 24 FLANGE NUT	PT # 0632	 x2 3/8" LARGE FLAT WASHER	PT # 3032	 x2 INFLATION VALVE AND VALVE CAP ASSEMBLY
PT # 3033	 x4 5/16" FLAT WASHER	PT # 3350	 x2 3/4" - 16 x 1 3/4" HEX HEAD BOLT	PT # 3046	 x2 AIR FITTING
PT # 3069	 x2 3/8" - 16 x 3/4" FLANGE BOLT	PT # 3295	 x4 3/4" - 16 HEX NUT	PT # 3012	 x4 3/8" - 16 x 3" CARRIAGE BOLT
PT # 3411	 x2 3/4" THICK WASHER	PT # 3412	 x2 3/4" - 16 FRAME NUT	PT # 9036	 x15 RED NYLON TIE
PT # 0070	 x8 3/8" - 16 x 1" HEX HEAD BOLT	PT # 3064	 x2 INTERNAL TOOTH LOCK WASHER	PT # 0899	 x2 THERMAL SLEEVE
PT # 3345	 x2 3/8" - 16 x 2 1/2" FLAT HEAD BOLT	PT # 3113	 x8 3/4" FLAT WASHER	PT # 3328	 x2 3/4" - 16 x 3" HEX HEAD BOLT
PT # 5428	 x1 FUEL LINE RELOCATION BRACKET				

# CONTENTS AND OVERVIEW

## SECTION 1

PAGE **4** REMOVE JOUNCE BUMPER, MOVE FUEL LINE AND BEGIN UPPER BRACKET INSTALL

PAGE **5** FINISH UPPER BRACKET INSTALL

PAGE **6** FASTEN AIR SPRING TO UPPER BRACKET

PAGE **7** INSTALL LOWER BRACKET ASSEMBLY

PAGE **8** SECURE LOWER BRACKET

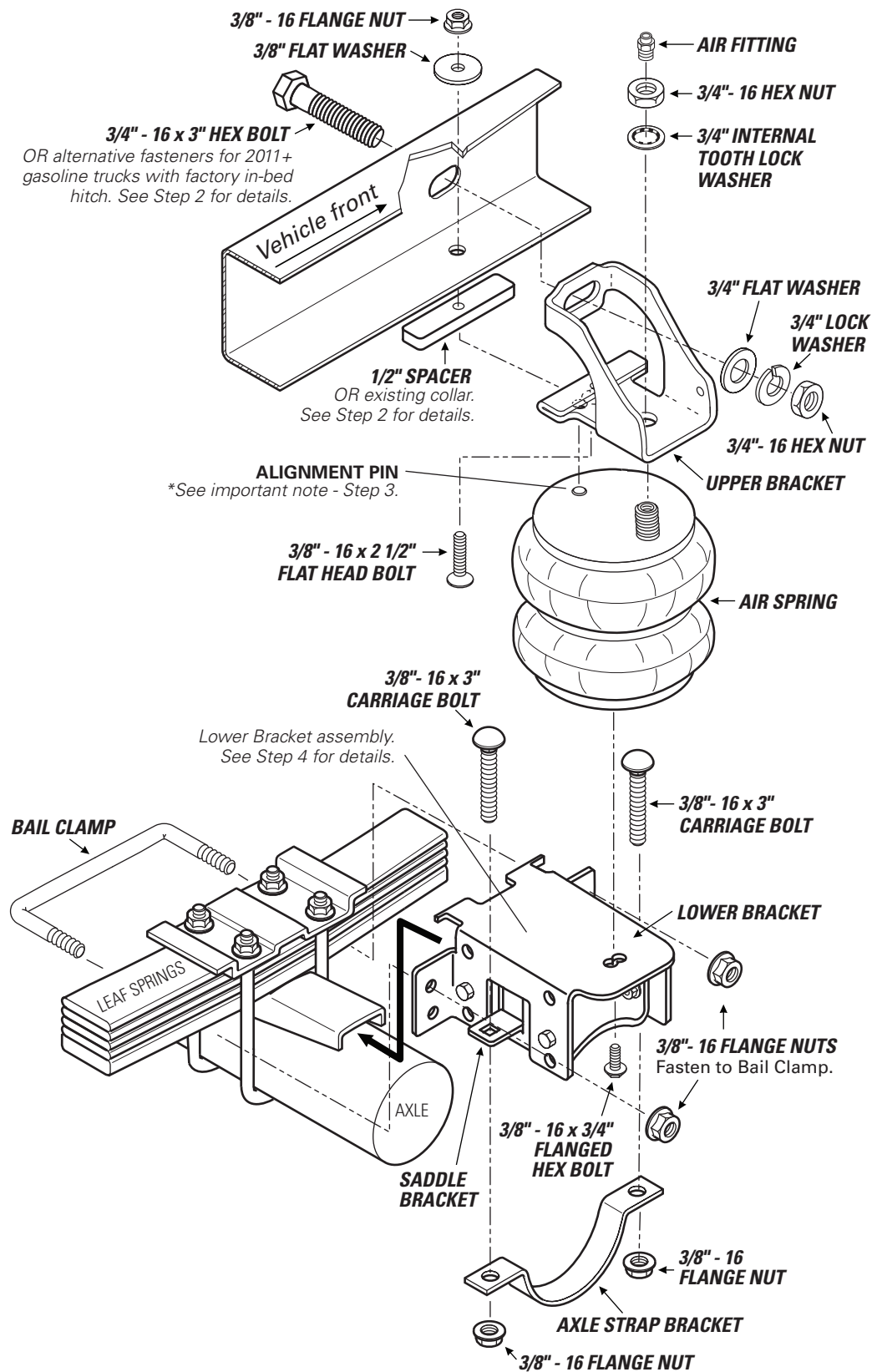

1

REMOVE EXISTING JOUNCE BUMPER & INSTALL RELOCATION BRACKET

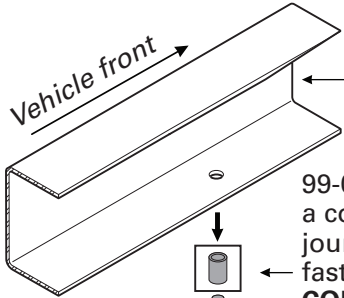
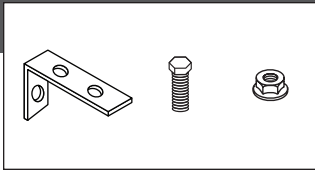

99-04 vehicles have a collar over the jounce bumper fastener. **KEEP THIS COLLAR. IT WILL BE USED LATER.**

JOUNCE BUMPER

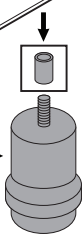

Unfasten and remove existing jounce bumper from the vehicle.

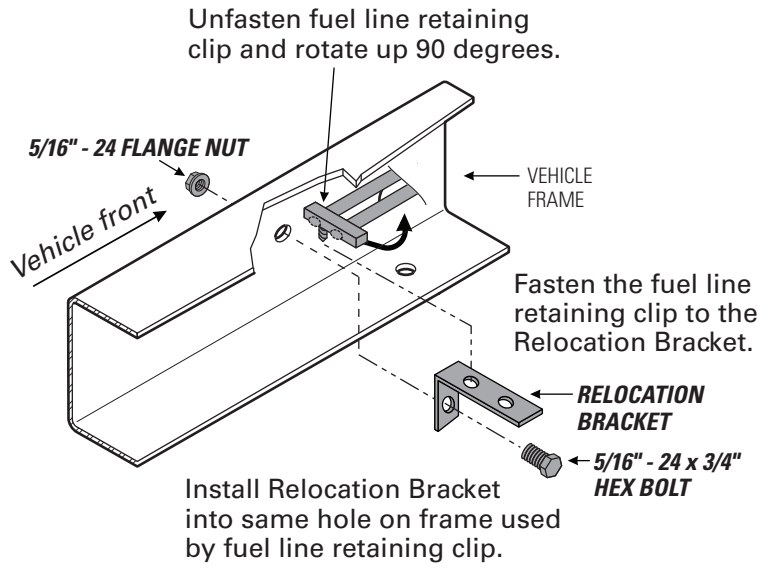

Install Relocation Bracket into same hole on frame used by fuel line retaining clip.

2

BEGIN UPPER BRACKET INSTALLATION

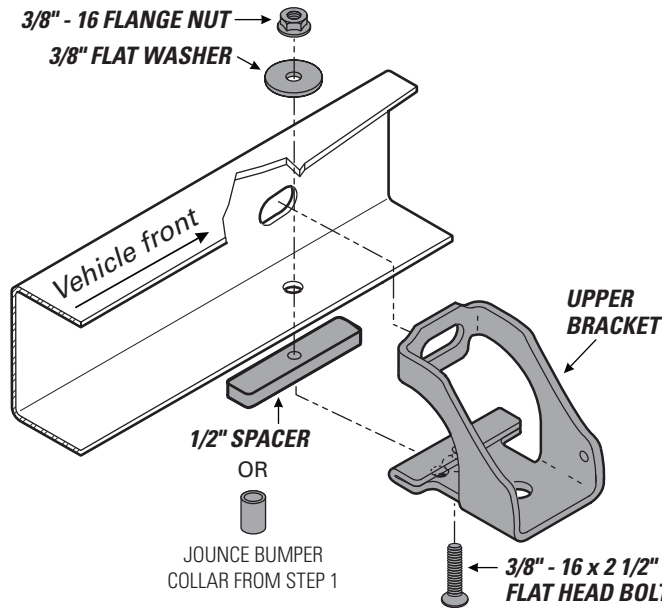
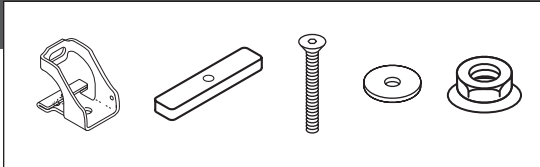

IF YOUR VEHICLE HAS THE COLLAR FROM STEP 1, IT MUST BE USED INSTEAD OF THE SPACER.

# 3

## FINISH UPPER BRACKET INSTALLATION

### A INSTRUCTIONS FOR ALL TRUCKS EXCEPT 2011+ GAS WITH FACTORY IN-BED HITCH

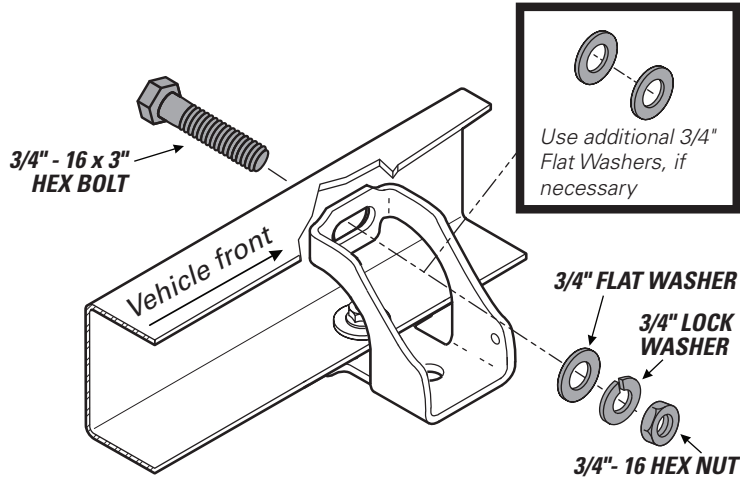
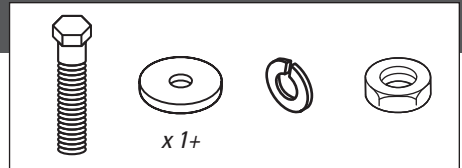

### B INSTRUCTIONS FOR 2011+ GAS TRUCKS WITH FACTORY IN-BED HITCH

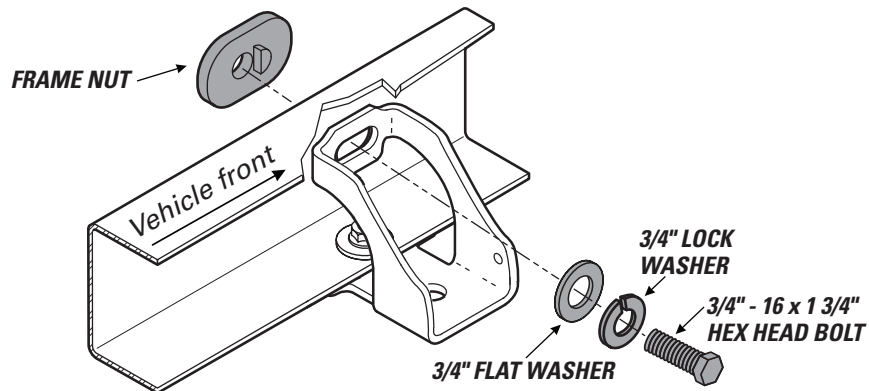
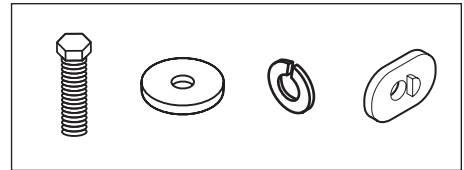

REMOVAL OF EXISTING IN-BED HITCH HARDWARE MAY BE REQUIRED.

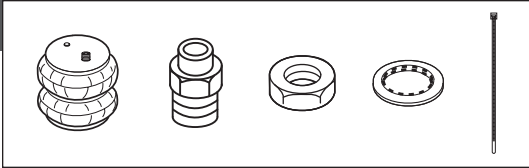

INSTALLING THE RIGHT SIDE? REMEMBER TO INSTALL THE HEAT SHIELD IN STEP 7 FIRST!

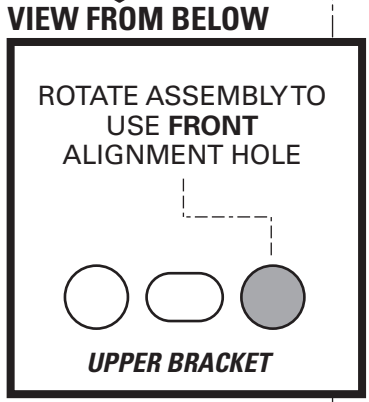
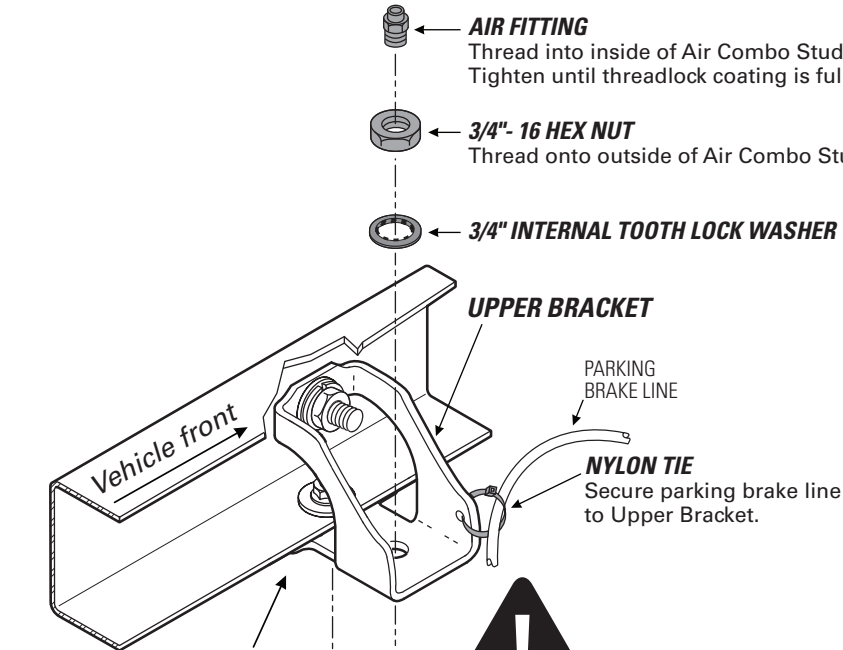

ALIGNMENT PIN ON AIR SPRINGS MUST BE INSTALLED TO FULLY SEAT INTO THE FRONT ALIGNMENT HOLE IN THE UPPER BRACKET. FAILURE TO DO SO WILL CAUSE IT TO BE PUSHED INTO THE BEAD PLATE, CREATING AN AIR LEAK, AND RESULTING IN AN AIR SPRING FAILURE THAT IS **NOT WARRANTABLE. THE ALIGNMENT PIN CANNOT HOLD 2,500 LBS! IT IS USED FOR ALIGNMENT ONLY!**

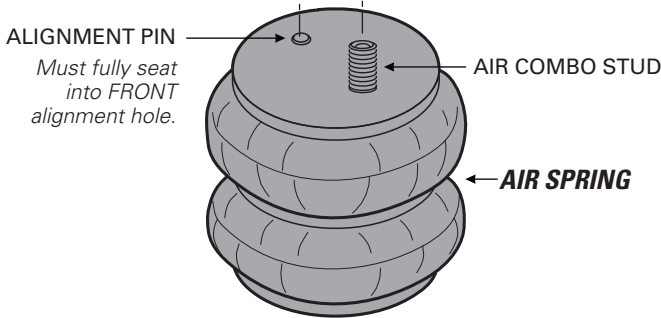

# 5

## INSTALL LOWER BRACKET ASSEMBLY

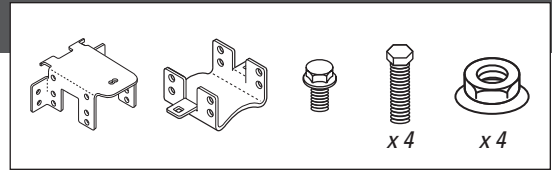

**1** Follow steps below to dry fit assembly. Make alignment marks as shown.

**2** Place bottom of Lower Bracket on the axle of the vehicle.

**3** Place the Upper Bracket above the Lower Bracket as shown. Assure both are tight against the leaf spring stack.

**4** Match the alignment marks and secure the Air Spring to the Upper Bracket, as shown.

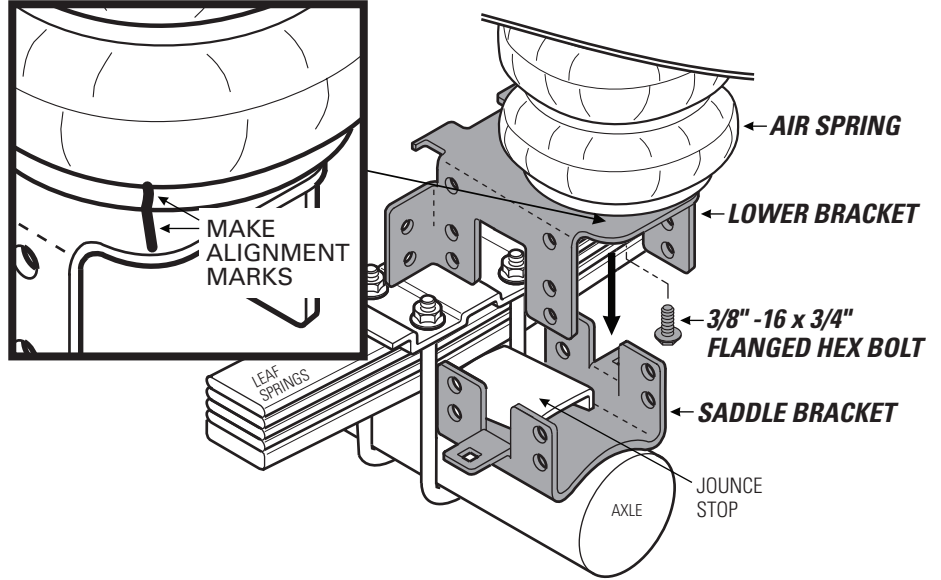

**5** Position the Lower Bracket as low as possible, while still clearing the jounce stop on the vehicle.

**6** Choose the bolt holes in both brackets that best line up with the Lower Bracket with the Saddle bracket. Make sure the Lower Bracket is parallel to the ground.

**7** Use supplied fasteners in the bracket holes you chose.

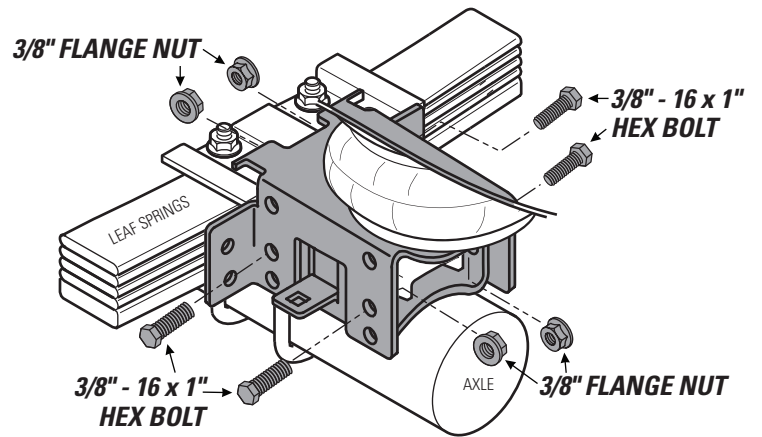

### ! IMPORTANT: INSTALL ON THE LOWEST SETTING POSSIBLE FOR YOUR VEHICLE

FAILURE TO DO SO CAN RESULT IN DAMAGED BRACKETS AND CAN VOID YOUR WARRANTY

#### 4-WHEEL DRIVE INCORRECT

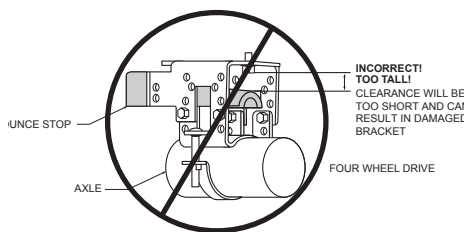

#### 4-WHEEL DRIVE CORRECT

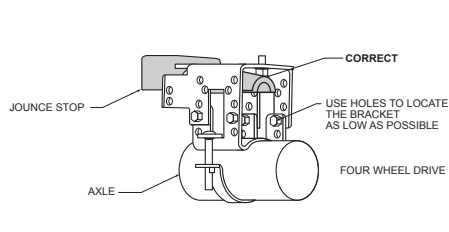

#### 2-WHEEL DRIVE CORRECT

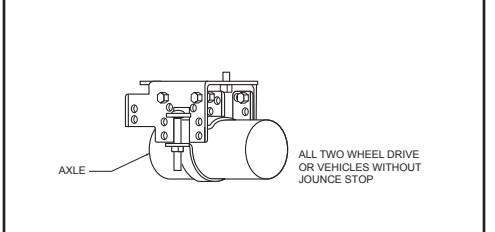



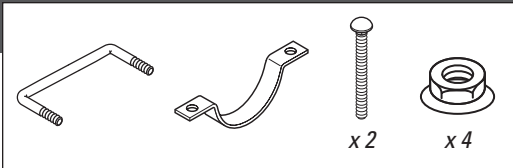

USE YOUR HAND TO CHECK FOR THE PROPER CLEARANCE AROUND THE AIR SPRING. IF YOUR HAND DOES NOT FIT BETWEEN THE AIR SPRING AND OTHER COMPONENTS, IT WILL RUB!

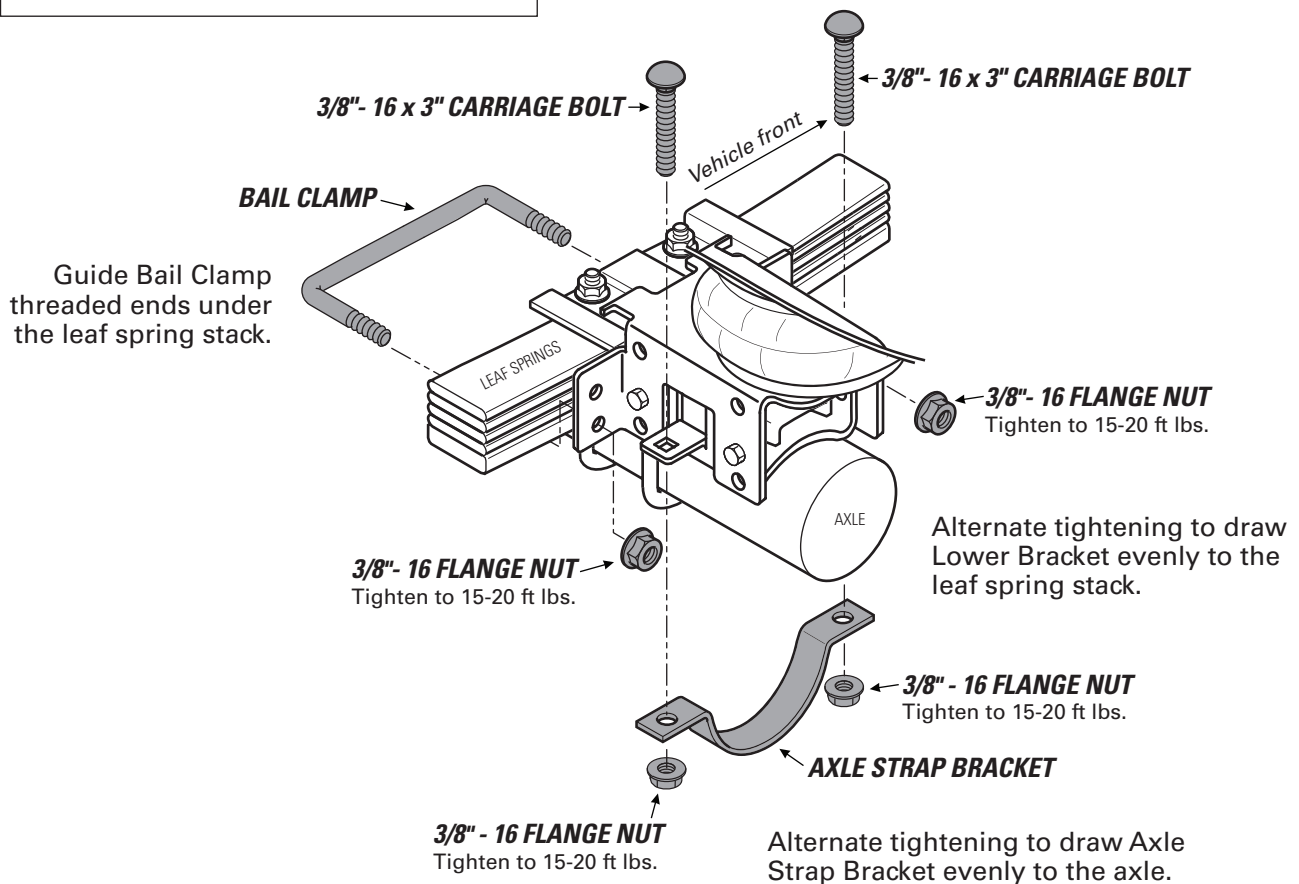

**AWESOME!** You're done with the left side. The right side is the same, with the addition of the Heat Shield. See Step 7, then complete the steps for the right side installation.

# 7

## INSTALL RIGHT SIDE WITH HEAT SHIELD

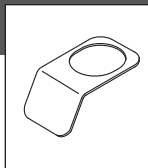

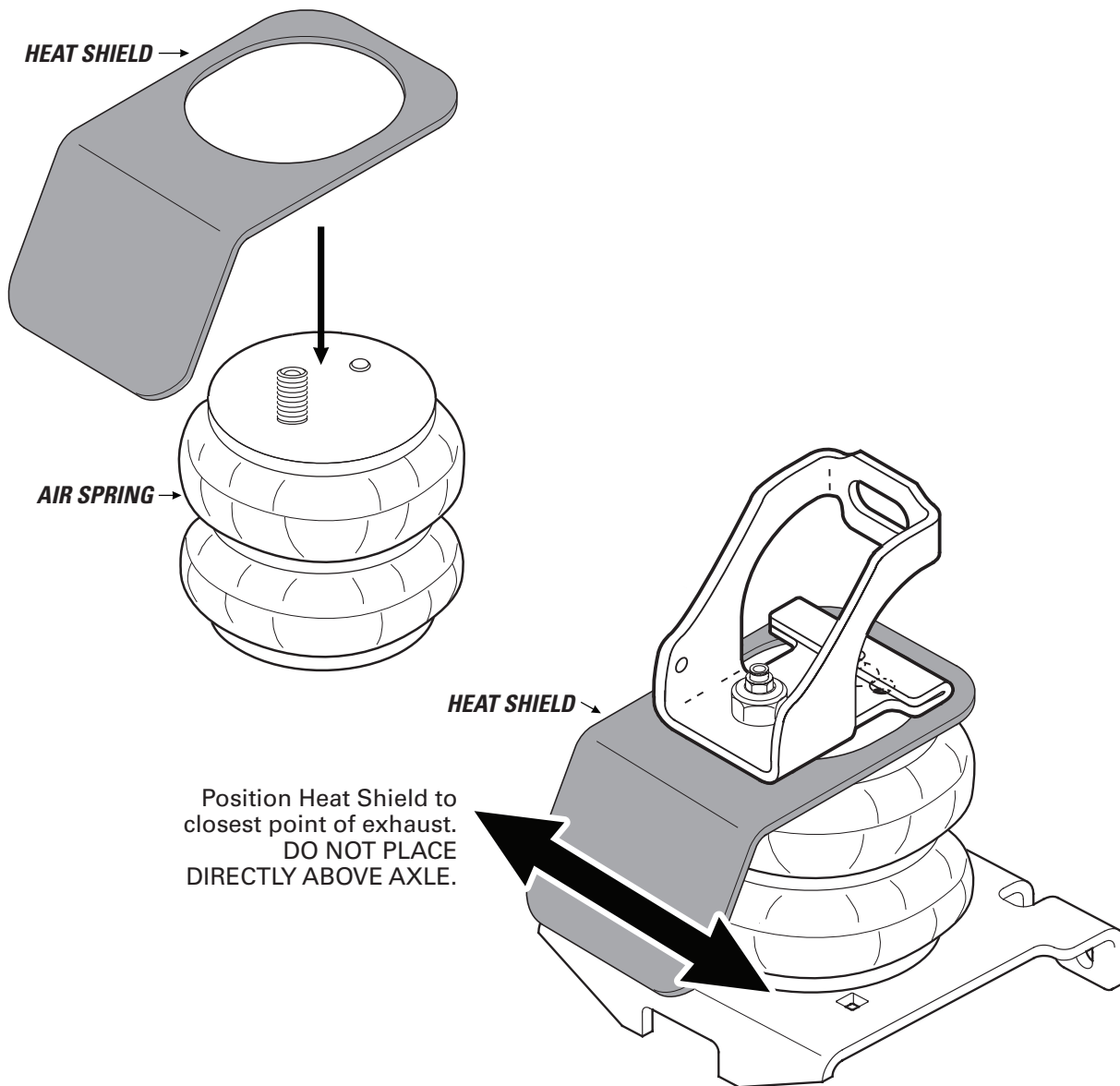

RIGHT SIDE INSTALLATION MUST INCLUDE HEAT SHIELD!







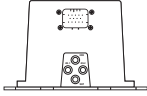
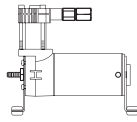
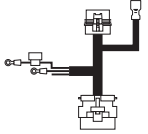
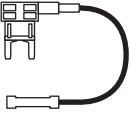





# SECTION 2 PARTS

Compare the parts below to your kit. Assure you have all pieces, and organize them for an easier installation.

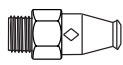
## AIR ACCESSORY CONTENTS

PT # 9490		x1 WIRELESS CONTROLLER	PT # 9489		x1 ECU	PT # 9523		x1 AIR COMPRESSOR KIT
PT # 9491		x1 WIRE HARNESS	PT # 2526		x1 IGNITION FUSE TAP	PT # 9414		x1 AIR LINE TUBE (18 FEET)

## A21-760-2581 HARDWARE PACK

PT # 3087		x4 10-32 x 1" MACHINE SCREW	PT # 3093		x3 10-32 x 3/4" MACHINE SCREW	PT # 3086		x13 3/16" FLAT WASHER
PT # 3088		x9 10-32 NYLOCK NUT	PT # 3055		x1 1/8 NPT PUSH-TO-CONNECT STRAIGHT FITTING	PT # 9361		x1 SEALED RELAY
PT # 3421		x1 10-16 x 3/4" SELF-TAPPING SCREW	PT # 9275		x4 VELCRO TABS	PT # 9036		x15 RED NYLON TIE
PT # 9488		x4 LARGE NYLON TIE	PT # 0899		x2 THERMAL SLEEVE			

# CONTENTS AND OVERVIEW

## SECTION 2

PAGE **12** PLANNING THE INSTALL

PAGE **13** PREPARE THE AIR COMPRESSOR

PAGE **14** DRILL HOLES FOR AIR COMPRESSOR AND ECU

PAGE **15** INSTALL THE AIR COMPRESSOR AND ECU

PAGE **16** INSTALL THE WIRE HARNESS

PAGE **17** INSTALL THE AIR LINE TUBES

PAGE **18** INSTALL THE AIR FILTER AND CLEAN UP

PAGE **19** USING THE WIRELESS CONTROLLER

PAGE **20** FREQUENTLY ASKED QUESTIONS

PAGE **21** TEST THE SYSTEM

PAGE **22** FIX AN AIR LEAK

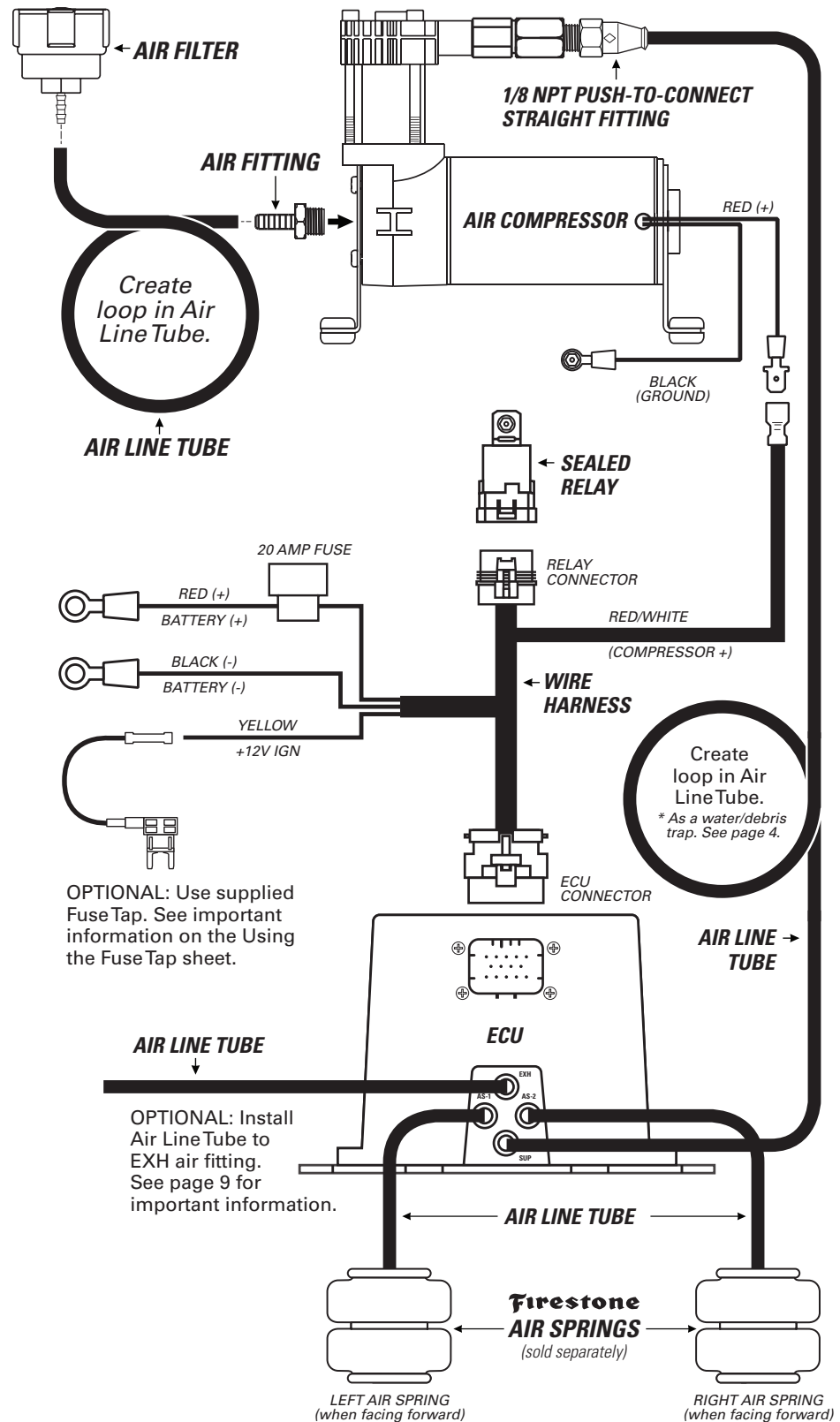

# PLANNING THE INSTALL

THESE PLANNING STEPS WILL HELP YOU SAVE TIME AND WILL MAKE THE INSTALLATION EASIER.

## **DETERMINE THE MOUNTING LOCATION FOR THE AIR COMPRESSOR**

- Provides ample air flow and is protected from airborne debris and moisture.
- Mount close enough to the ECU to allow Wire Harness connections to reach.
- If using the optional Firestone Air Accessory Mounting Kit, consider the guidelines above, and follow the kit's instructions.

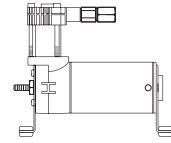

## **DETERMINE THE MOUNTING LOCATION FOR THE ECU**

- Mount close enough to the Air Compressor to allow Wire Harness connections to reach.
- Allow room for Air Line Tubes to connect to the air fittings on the ECU.
- Allow room for the 14-pin ECU connector to connect to the ECU.
- Allow room for the Air Line Tube to run without sharp curves or bends.
- Using supplied fasteners shown in Step 3 is recommended. If no other mounting option is available, see the sidebar on Step 2 for using the Large Nylon Ties.
- Select a location that is solid and secure on the body or frame of the vehicle, away from any moving parts, electrical or any other lines.

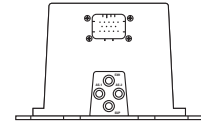

## **PLAN INSTALLATION ROUTES FOR WIRING AND AIR LINES**

- Make sure the Wire Harness and Air Line Tubes are not exposed to sharp metal edges that can damage them.
- Use supplied Thermal Sleeves on Air Line Tubes when routing near heat sources.
- Use supplied Nylon Ties to secure Air Line Tubes and Wire Harness to the vehicle.
- Make a loop in the Air Line Tube where shown. This creates a water/debris trap that protects the Air Compressor.
- Measure twice, cut once!

## **TAPE ALL ELECTRICAL CONNECTIONS**

- Use electrical tape to appropriately secure and protect all electrical connections.

## **USING PUSH-TO-CONNECT FITTINGS FOR AIR LINES**

Your kit includes Push-to-Connect fittings to connect the Air Line Tubes to hardware. Use the instructions below when using the Air Line Tubes.

- 1** Insert end of Air Line Tube into air fitting.

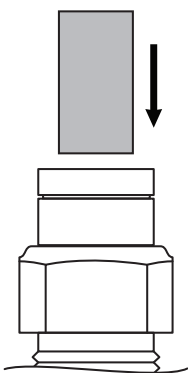

- 2** Push Air Line Tube into air fitting as far as possible.

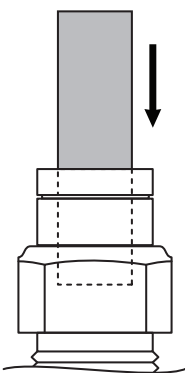

- 3** Gently pull on the Air Line Tube to check for a secure fit.

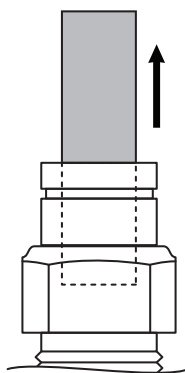

- 4** To remove, push down collar and gently pull Air Line Tube away.

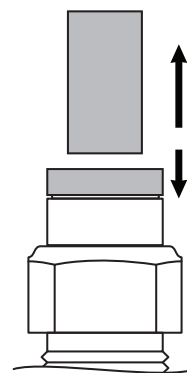

**Removal Tip:** Use a 1/4", 5/16", or 6mm open-ended wrench to push the collar down.

# 1

## PREPARE THE AIR COMPRESSOR

*NOTE: Air Compressor can be mounted facing any direction.*

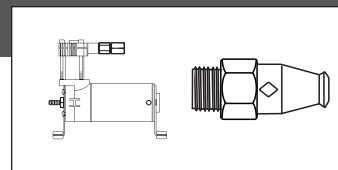

- 1 Install 1/8 NPT Push-to-Connect Straight Fitting on the Check Valve.

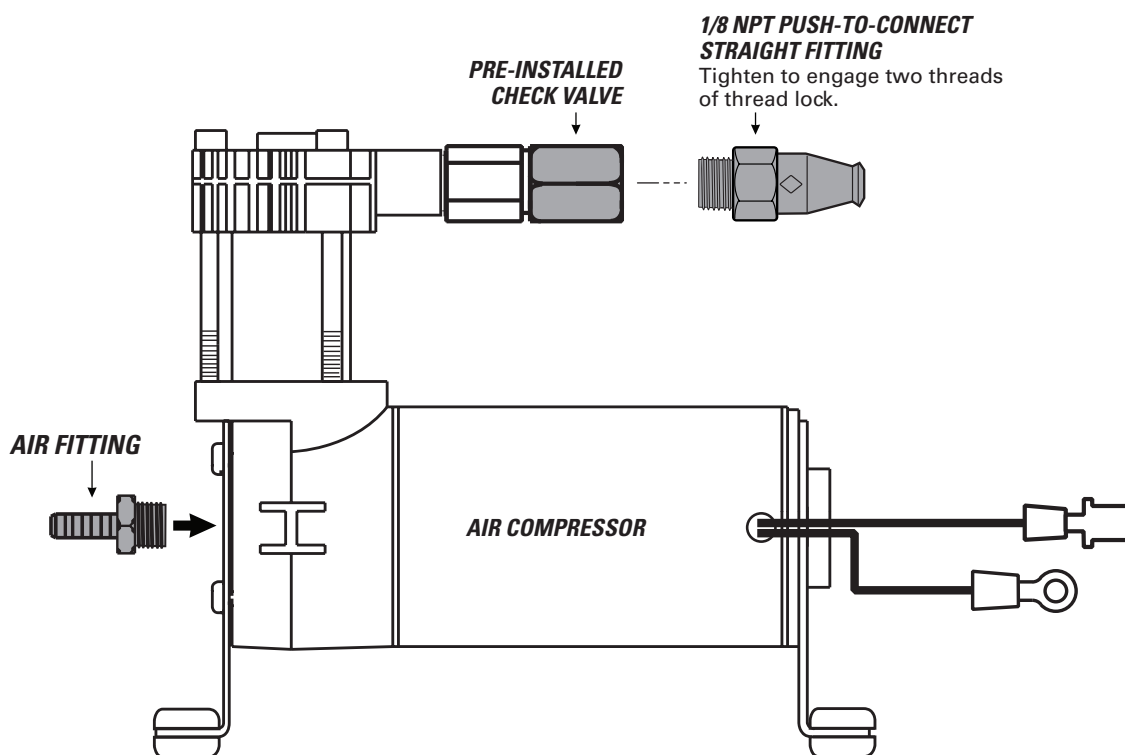

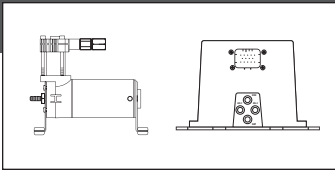

CHECK SURROUNDING AREA AND BACK SIDE OF MOUNTING LOCATION TO AVOID DRILLING INTO EXISTING LINES OR WIRING.



IF YOU ARE USING THE OPTIONAL FIRESTONE AIR ACCESSORY MOUNTING KIT, SKIP THIS STEP AND REFER TO THE MOUNTING KIT'S INSTRUCTIONS.

Drill within reach of the ground wire ring terminal on body or frame of vehicle. **AIR ACCESSORY MOUNTING KIT CANNOT BE USED AS A GROUNDING LOCATION FOR THE AIR COMPRESSOR.**

**1** Using the Air Compressor and ECU as templates, mark drill locations as shown with a punch or marking tool.

**2** Mark Air Compressor ground wire fastening location within reach of the ground wire ring terminal.

**3** Drill 3/16" diameter holes. Remove any burrs and debris from drill holes.

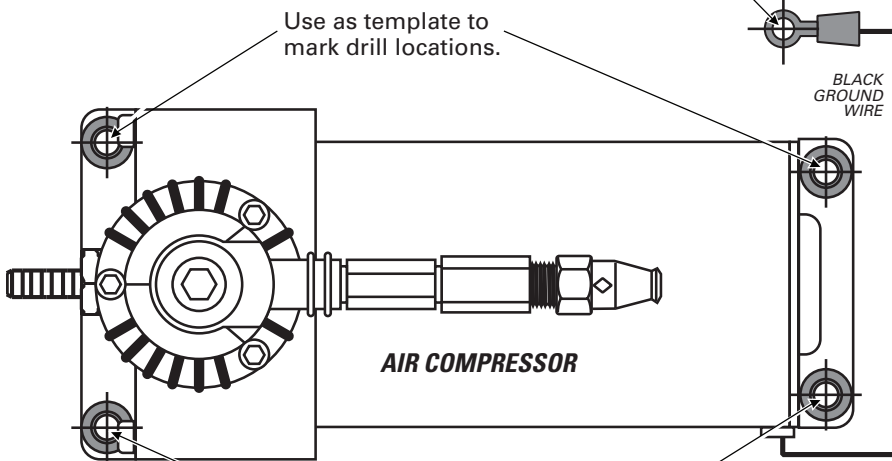

ASSURE THAT YOU INSTALL THE AIR COMPRESSOR AND ECU CLOSE ENOUGH SO THE CONNECTORS ON THE WIRE HARNESS WILL REACH THEM BOTH.



Use as template to mark drill locations.

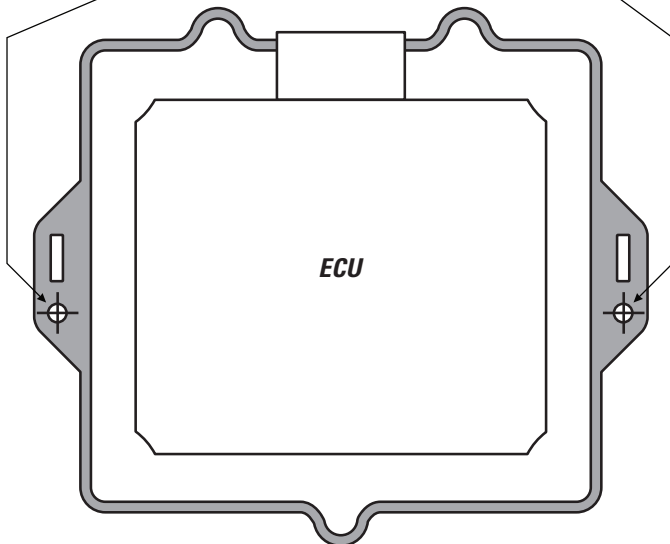

**OPTIONAL ECU MOUNTING**

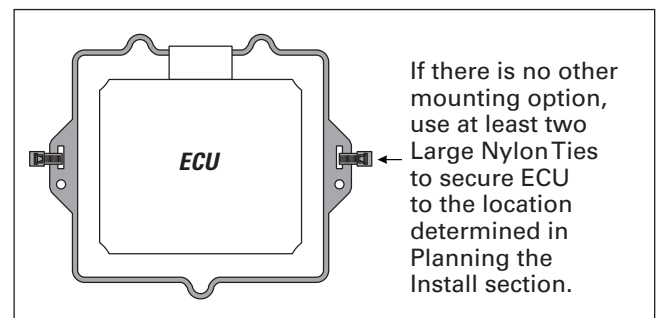

# 3

## INSTALL THE AIR COMPRESSOR AND ECU

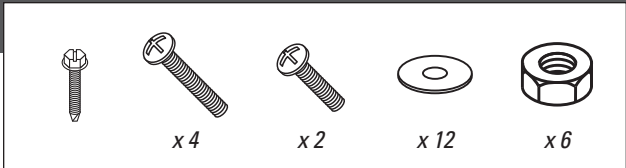

DO NOT OVER TIGHTEN MOUNTING BOLTS AND NUTS ON THE AIR COMPRESSOR. TOO MUCH TORQUE CAN CRUSH THE BRASS INSERTS AND RUBBER ISOLATORS.

**1** Mount the Air Compressor to the drill hole location using the supplied fasteners. DO NOT OVERTIGHTEN.

**2** Mount the ECU to the drill hole location using the supplied fasteners.

**3** Mount the black ground wire ring terminal using the supplied fasteners. Assure that the ring terminal makes a solid contact with bare metal for a proper ground.

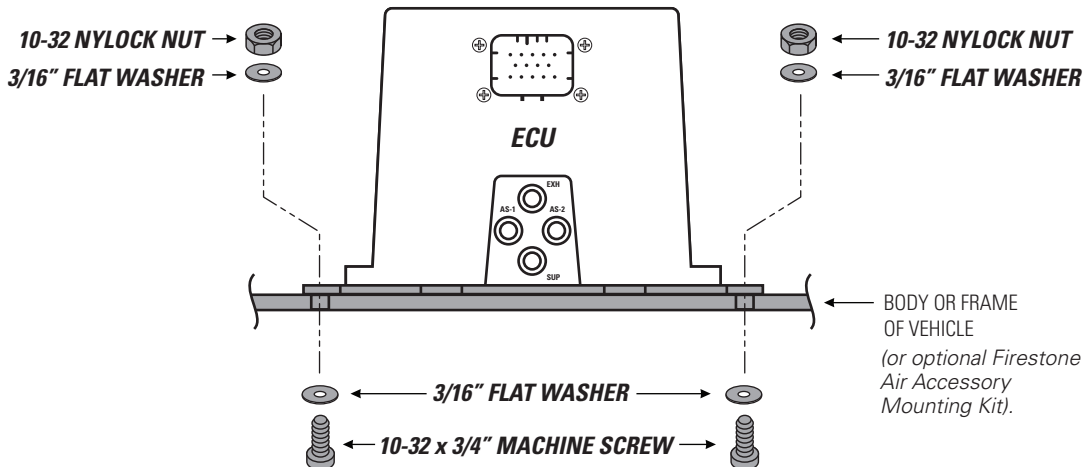
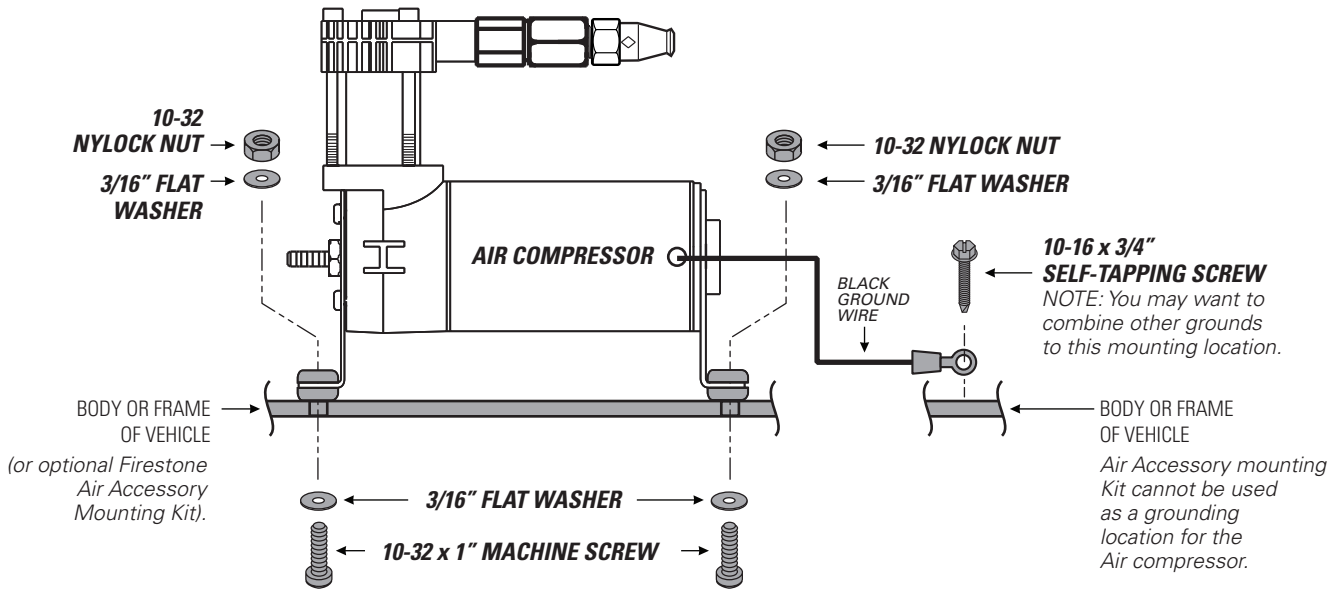



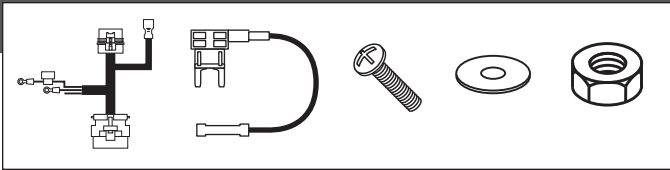

Why ground the Wire Harness to the battery? The ECU needs a good, clean ground for optimal accuracy. The Air Compressor can ground to the frame, but the ECU cannot.

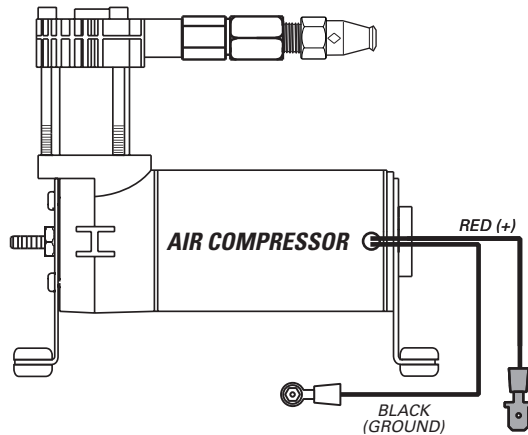

10-32 NYLOCK NUT  
3/16" FLAT WASHER  
10-32 x 3/4" MACHINE SCREW

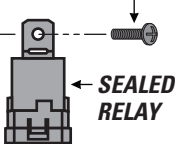

Drill 3/16" hole in suitable location on vehicle (or use optional Firestone Air Accessory Mounting Kit).

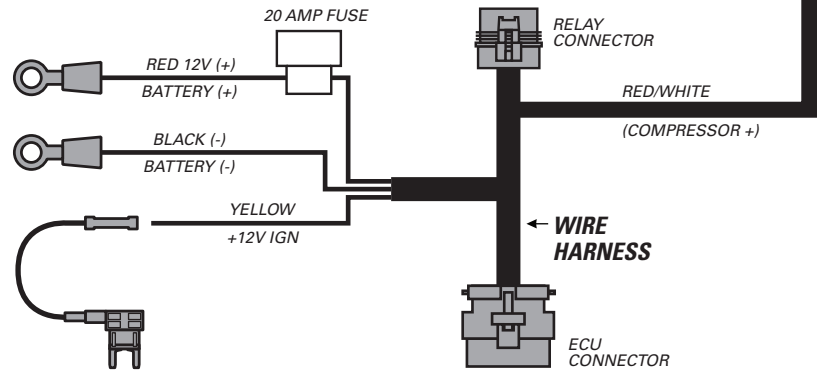

OPTIONAL: Use supplied Fuse Tap. See important information on the Using the Fuse Tap sheet.

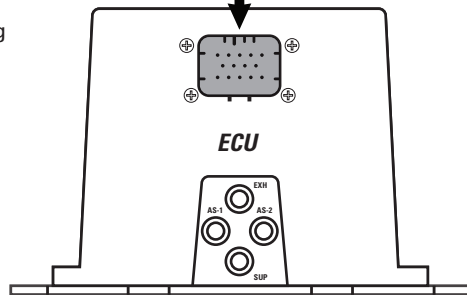

**1** Determine a suitable location to mount the Sealed Relay, assuring it will be within reach of the relay connector on the Wire Harness.

**2** Securely fasten the Sealed Relay as shown.

**3** Route the Wire Harness in the most protected manner possible, and securely make all connections as shown.

**TAB CONNECTOR EXAMPLE**

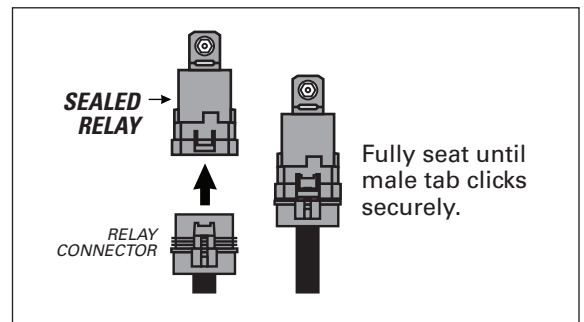

# 5

## INSTALL AIR LINE TUBES

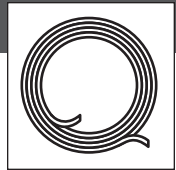

EXHAUST ALL AIR FROM THE SYSTEM PRIOR TO RELEASING AIR TUBES FROM AIR FITTINGS.



**1** Route the Air Line Tube from 1/8 NPT Push-to-Connect Straight Fitting on the top of the Air Compressor to the Supply (SUP) air fitting on the ECU, leaving room to secure it safely. Use the guidelines on page 4 for proper Push-to-Connect Straight Fitting install.

**2** Repeat Steps 1 to route Air Line Tube from the ECU to the Air Springs. Use the AS-1 and AS-2 air fittings on the ECU.

**3** If desired, install Air Line Tube to the Exhaust (EXH) air fitting to reduce exhaust noise and prevent dirt from clogging the port (recommended for off-road or dirty environments). Do not exceed 16" of Air Line Tube, and secure it so the end turns to the ground.

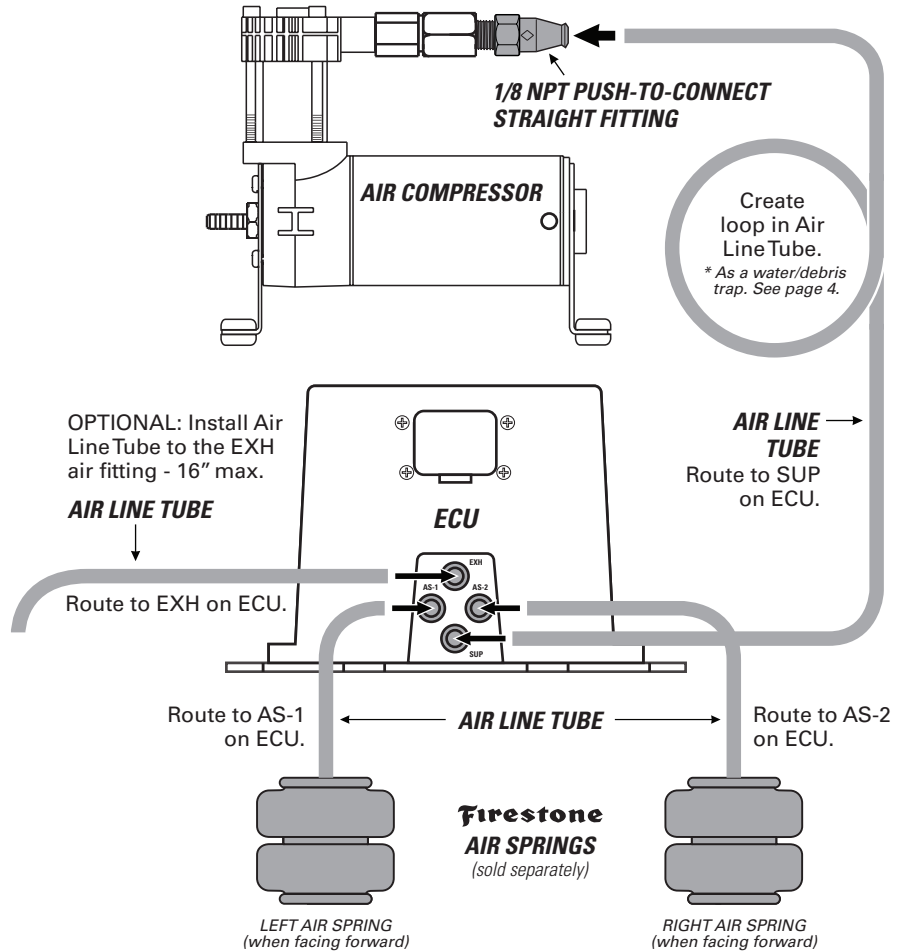

# DO

Make sure the cut is as square as possible. Use a tube cutter or very sharp utility knife.

# DON'T

Fold or kink the Air Line Tube. Cut the Air Line Tube at an angle. Use pliers, scissors, snips, saws, or side cutters.

### PROPER AND IMPROPER CUTS IN THE AIR LINE TUBE

<p>Square cut AIR LINE TUBE 90°</p>	<p>AIR LINE TUBE</p>	<p>AIR LINE TUBE</p>	<p>AIR LINE TUBE</p>
---	----------------------	----------------------	----------------------

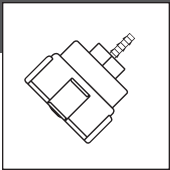

FILTER LIFE WILL VARY BASED ON ENVIRONMENTAL CONDITIONS. PROTECT THE AIR COMPRESSOR BY CHANGING THE AIR FILTER MORE FREQUENTLY IN DUSTY CONDITIONS.

**1** Fully secure the Air Filter barb into the Air Line Tube from the Air Compressor Kit.

**2** Press Air Line Tube onto the barb on the Air Compressor Air Fitting until fully seated. Assure you create a loop in the Air Line Tube, as shown, when securing it to the vehicle.

**3** Periodically check the Air Filter during operation. When the Air Filter is dirty and needs to be replaced, contact an Authorized Firestone dealer to purchase a new one.

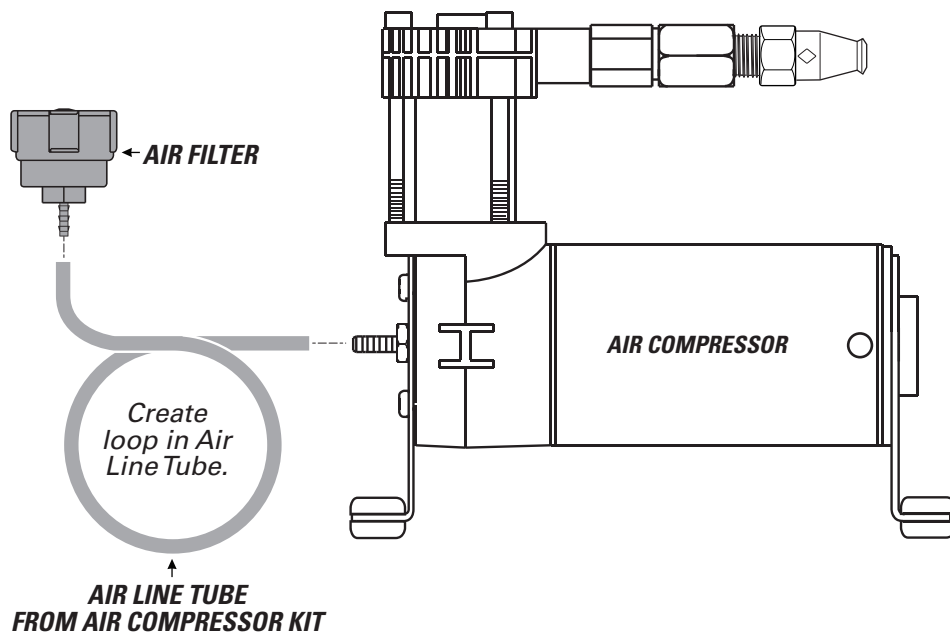

**1** Clean up the installation using supplied Nylon Ties, and return all factory parts and materials to operative state.



USING SUPPLIED NYLON TIES, SECURE ALL WIRING AND AIR LINE TUBE IN A MANNER THAT DOES NOT OBSTRUCT MOVING PARTS OR IN ANY WAY THAT AFFECTS YOUR ABILITY TO SAFELY OPERATE THE VEHICLE.

# 8

## USING THE WIRELESS CONTROLLER

Use the Wireless Controller to adjust the air pressure in your Air Springs. You can select the Air Springs individually, or both at the same time. Determine sides when in vehicle, facing forward. If desired, use the supplied Velcro Tabs to secure the remote to the vehicle.



### F3 REMOTE FUNCTIONS

#### On/Off

Press **Enter** to turn on remote. Hold **Enter** button for 3 seconds to turn off remote.

#### Inflating/Deflating Pressure for Both Air Springs

Turn on the remote to enter the main menu. Press **Enter** to adjust both air springs. Adjust pressure by pressing **(+)** or **(-)** button to desired pressure setting. Press the **Enter** button when desired setting is reached.

#### Inflating/Deflating Pressure for Individual Air Springs

Turn on the remote to enter main menu. Press **Enter** to adjust both air springs. Press **Enter** again to adjust individual air springs. Adjust pressure by pressing **(+)** or **(-)** button to the desired pressure setting. Press the **Enter** button when the desired setting is reached.

#### 2 Memory Button Settings

Press **M1** or **M2** button. Preset pressure should appear. M1 is preset to 5 PSI. M2 is preset to 20PSI. Press the **Enter** button again to adjust pressure. To change the preset pressure, press **M1** or **M2**. Change the preset pressure by pressing **(+)** or **(-)** button. To save the pressure setting to memory, press and hold **Enter** button for 3 seconds. The display will flash rapidly to indicate the new pressure setting is saved. After saving the new pressure, the menu will revert to main menu.

#### Changing Units to PSI/BAR

Press **(+)** and **(-)** buttons together for 3 seconds. Once in the unit measurement menu, press **(+)** for PSI and **(-)** for BAR. Press **Enter** again to save the desired unit measurement and revert back to main menu.

#### Tank Mode

To convert to Tank Mode, unplug power to the ECU, install the tank and repower the ECU. The system will automatically enter Tank Mode.

#### Tank Mode Menu

Press and hold **M1** and **M2** buttons for 3 seconds to enter Tank Mode. While in Tank Mode, **T** will appear on the top row and the current tank pressure on the bottom row. Preset tank pressure range is 110-145/90-120. M1 is preset to 110/145. M2 is preset to 90/120. *Note: In Tank Mode, it is not advised to set air springs above Tank Pressure lower limit. User should first raise the lower limit threshold to a higher range before increasing pressure in Air Spring.*

### F3 REMOTE ERROR CODES

#### Error Definition

**Communication Error:** An error message **E/CN** will display if communication from the ECU to the remote is not established for 2 seconds.

**Leak Error:** The remote will display **EL** in the top row if a leak is present and either **t**-tank, **L**-left air spring or **r**-right air spring on the bottom row to notify which component is leaking.

**Bad Pressure Sensor:** The remote will display **EP** in the top row if a bad pressure sensor is present and either **t**-tank, **L**-left air spring, **r**-right air spring in the bottom to notify which component has the bad pressure sensor.

**Compressor Error:** The remote will display **EC** on the top row if the compressor exceeds 4 minutes of runtime.

**Low Battery:** The remote will display **Lo Bt** on the display if batteries are below the rated voltage of 3.0 V. *Note: when the low battery indicator is present, the remote will be unable to save the last setting by the user.*

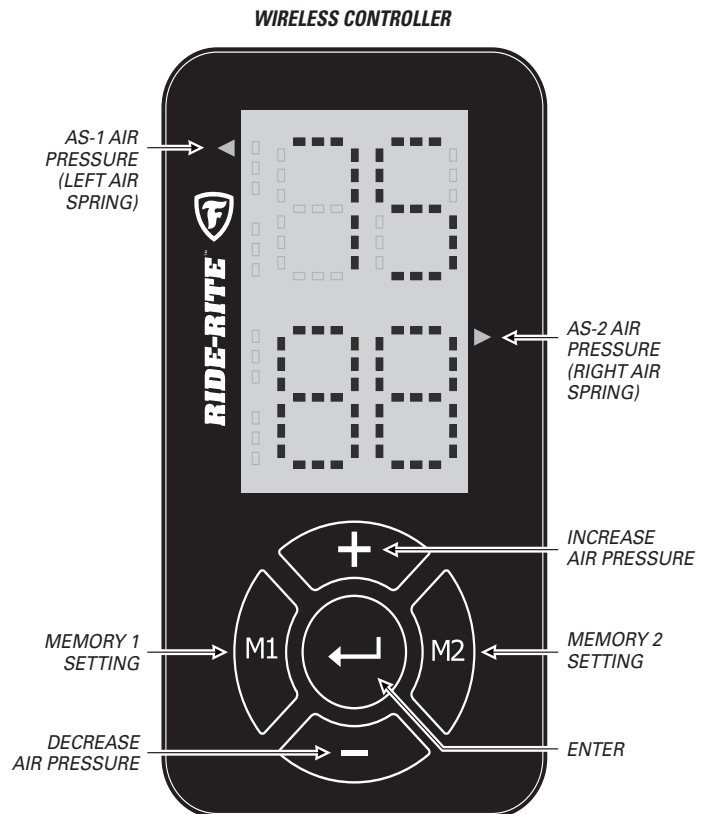

**1) Why is my system not powering up?**

When the system does not power up, usually this is a strong indication of improper power and grounding. Ensure that the power line (red wire) is attached to a +12 volt power source (battery). The grounding line (black wire), should be rerouted back to the battery, not the frame of the car. Traditionally, techs have used the frame the car as a grounding source, but through experience, we have seen that using the true ground (battery) offers the best connection for the device. Next, ensure that the yellow line is connected to the ignition fuse located in your vehicles fuse box. Please make sure the fuse on the F3 wiring harness is installed and not blown. It is important to confirm with a meter (if possible) that the fuse is on only when the ignition is engaged and off when the ignition is off.

**2) Why are my buttons not responding correctly?**

When your remote controller appears to not operate as intended, some of the key items you need to check are: battery charge (+3v), proper connection to the ECU, EC/N Code (refer to #7), barriers that are in between the ECU and the remote, proper powering (refer to #1).

**3) Why is my compressor not shutting off?**

When your compressor stays on even after the ignition switch has been placed to the off position, please ensure that the yellow line is tied to a switched fuse in the fuse box. To ensure this, please use a volt meter to confirm that the line is on (+12v), if and only if the ignition switch is in the ON position, and OFF when in the off position.

**4) My remote does not work inside my cabin. What should I do?**

With the improvements in technology, some cars are equipped with other electronic equipment which may cause interference to the F3 system. Others vehicles are equipped with noise canceling material and equipment which also play a role in the interference of the F3 connectivity. To check if either of these scenarios is true, confirm that your unit works properly if operated outside. If your unit does operate as intended outside the vehicle, contact us for further solutions.

**5) Why does my system not turn on when I turn the ignition on?**

When your F3 system does not turn on when the ignition switch is on the on position, this is a strong indicator that the unit is not powered/grounded correctly. Please refer to question #1.

**6) Why does my remote freeze when I am trying to change pressure?**

When your remote is freezing, this is an indication that the communication is out of range/ batteries have insufficient charge or you may have a bad remote. If the batteries are low, replace the batteries. If the communication range is over 30 meters, operate the unit in close proximity. If the issue still persists, contact our tech line to receive a replacement. In order to receive a placement, please have your receipt to show proof of purchase.

**7) Why does my remote display "E/CN" when attempting to change pressure?**

The "E/CN" code is an indicator that the remote is not communicating to the ECU. When this occurs, this is an indicator that the ECU is not powered or the user is out of range. When the ECU is not powered, please refer to question #1. If the user is out of range, ensure to get within the range of 30meters (98 feet).

**8) What should I do when the remote goes to sleep before it meets the set pressure?**

Check battery voltage.

**9) Is it normal for my compressor to be overworking when attempting to reach pressure?**

When the compressor sounds as if it is overworking to get to pressure, relax. This is normal. The ECU was programmed to reach the designated pressure as accurately as possible. To reduce the over usage of the compressor, use the system only when needed. Having two preset settings will reduce the over usage and increase the system lifetime.

**10) Why does my compressor run while exhausting continuously?**

When the compressor exhausts while running, ensure that the air line connections to the ECU are correct. The ECU has a supply and exhaust line. If the unit is connected backwards, the ECU will attempt to reach pressure, but won't since the connection is improper. If the issue persists after confirming proper connection, check the valves next. The valve could have debris which is not allowing the valves to properly close. If shop air is available, engage the valves with air to free the valves of debris. If the issue persists, please contact tech line for warranty claim.

**11) Why does my compressor turn on and run by itself while driving?**

If the compressor turns on by itself while the vehicle is in motion and continuously runs, there is a relay that is energized by the battery, and there is a potential wiring harness connection problem. It is possible that the ground terminal of the harness is improperly connected, or has become loose. Please check the connections of the harness to ensure that all terminals are properly connected. If all connections are secure and properly connected, please check the integrity of the relay connection to the compressor. It may be possible that the relay is failing or has failed.

**12) Why does my compressor still run when I turn the key off, even when wired to an ignition source?**

Please confirm that the following are connected correctly:

- A: The yellow ignition wire is properly connected to the correct fuse that connects to a switched source. There are some fuses that are always powered even when the vehicle's ignition is turned off.
- B: The red power wire is properly connected to the battery, preferably directly to the battery terminal to ensure that the relay is properly energized and reenergized during turn-on, turn-off cycles.
- C: The black wire is properly attached to a ground path. A direct battery connection to the negative terminal is preferred.

**13) Why does my compressor run, but dead heads at the ECU?**

The compressor usually stops operating if there is an improper connection to the valve body inlets and outlets. If your compressor runs momentarily and then stops, please check the following:

- A: The battery on the vehicle is in good working condition. It has been observed that batteries with insufficient capacities have been unable to withstand compressor demands. Please check your compressor's power rating, and confirm that the battery can meet the voltage and current demands.
- B: Please confirm that the air lines are connected to their proper inlet or outlet valves. This will enable the compressor to properly operate as demanded by the user's input.

**14) Why does my controller show a completely different pressure than what is actually in the bags?**

When the controller shows a completely different pressure, please contact our tech line for a warranty claim. The ECU contains pressure sensor which can be faulty. Since the sensors are inside the ECU, the unit needs to be replaced.

# 10

## TEST THE SYSTEM

With the Air Command™ F3 Kit and your Air Springs installed, you are ready to test the system.

- 1 Reattach the negative battery cable.

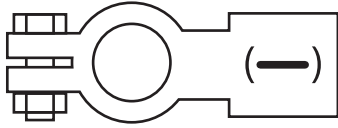

- 2 Turn on your vehicle's ignition.

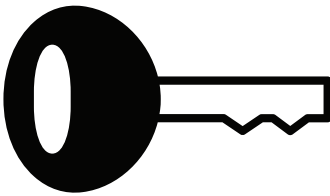

- 3 Use the Wireless Controller to inflate the Air Springs to 70 PSI. See Step 8 for details.

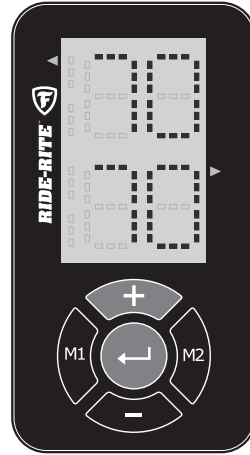

- 4 Spray fittings with soap and water mixture or glass cleaner.



- 5 Observe bubbles.

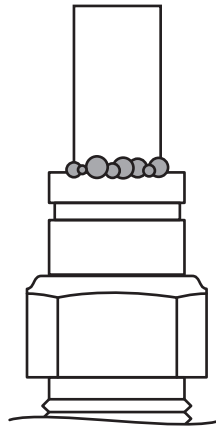

**SMALL SOAP BUBBLES  
THAT DO NOT EXPAND**

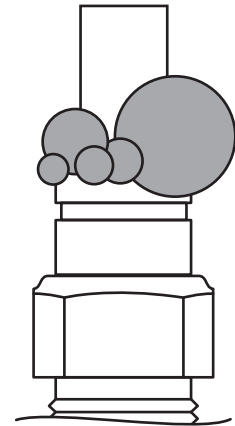

**SOAP BUBBLES  
THAT EXPAND**



# NO LEAKS?

Congratulations! You're riding right with the push of a button! Remember to review the Operating Instructions.

# LEAK?

Bummer. Continue to Step 11 to fix the leak.



EXHAUST ALL AIR FROM THE SYSTEM PRIOR TO RELEASING AIR TUBES FROM AIR FITTINGS.



- 1 Use the Wireless Controller to deflate the Air Springs to 5 PSI. See Step 8 for details.

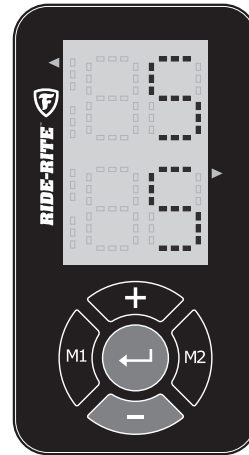

#### LEAK AT AIR LINE TUBE AND AIR FITTING

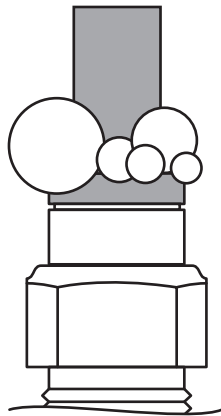

Release Air Line Tube (see page 4). Review proper cuts and procedures in Step 5. Repeat Step 5.

#### LEAK AT BASE OF AIR FITTING

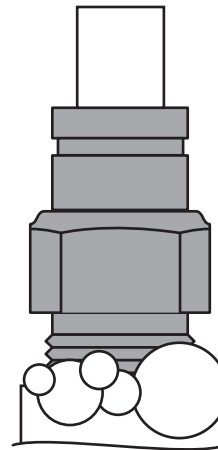

Tighten Air Fitting one turn or until leak stops.

## STILL HAVE A LEAK?

Refer to the Troubleshooting section of the Instruction Manual. If the leak persists, or if there is an issue with a leaking part, call 1-800-888-0650; Option 1; Option 1 for Tech Support.



[riderite.com](http://riderite.com)

### **SAFELY RETURN VEHICLE TO OPERATIVE STATE**

If you removed any wheels during installation, install the wheels and torque the lug nuts to the manufacturer's specifications. Safely remove any jack stands and wheel chocks used during installation. Re-attach the negative battery cable.

### **READ AND UNDERSTAND THE OPERATING INSTRUCTIONS**

The Ride-Rite system can improve handling and comfort. Take the time to learn how to properly use and maintain your investment by reading the Operating Instructions.

### **BEFORE YOU DRIVE, CONFIRM THE FOLLOWING:**

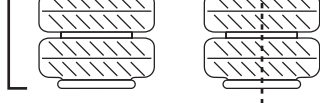
- Do you have a minimum of 5PSI in your Air Springs? **5 1/2" - 7"**
- Are your Air Springs standing 5 1/2 - 7" tall? 
- Are your Air Springs properly aligned, left-to-right and front-to-back?
- Are your nuts and bolts tight?
- Put your paper work back into the sleeve and keep it in your glove compartment for future reference.
- Secure all Air Line Tubes and wiring.
- The system passes the leak test and holds air.
- The Air Compressor ground ring terminal is contacting bare metal, and coated with silicone if possible.
- The Wire Harness is grounded to the negative (-) battery terminal. The ECU needs a good, clean, interference-free ground.
- There is a loop in the Air Line Tubes as shown to prevent water or debris from getting into the Air Compressor head and damaging it.
- You've been bagged...and now your suspension is Airide equipped! Show it off with the supplied decal!

## **NEED INSTALLATION HELP? 1-800-888-0650**

Select Option 1 for Ride-Rite; Select Option 1 for Technical Support.

Or, email us at [rrtech@fsip.com](mailto:rrtech@fsip.com). If emailing, please include photos to help us better diagnose and understand any problems you may be experiencing.

# **Firestone**

Firestone Industrial Products

CONNECT WITH US



@firestoneip



FirestoneIP



Firestone Ride-Rite



# **COMBO STUD NOTICE:**

THE ALIGNMENT PIN ON THE AIR SPRING **MUST** BE INSTALLED INTO THE HOLE IN THE UPPER BRACKET.

FAILURE TO DO SO WILL CAUSE THE ALIGNMENT PIN TO BE PUSHED INTO THE BEAD PLATE, CREATING AN AIR LEAK, AND RESULTING IN AN AIR SPRING FAILURE THAT IS **NOT WARRANTABLE.**

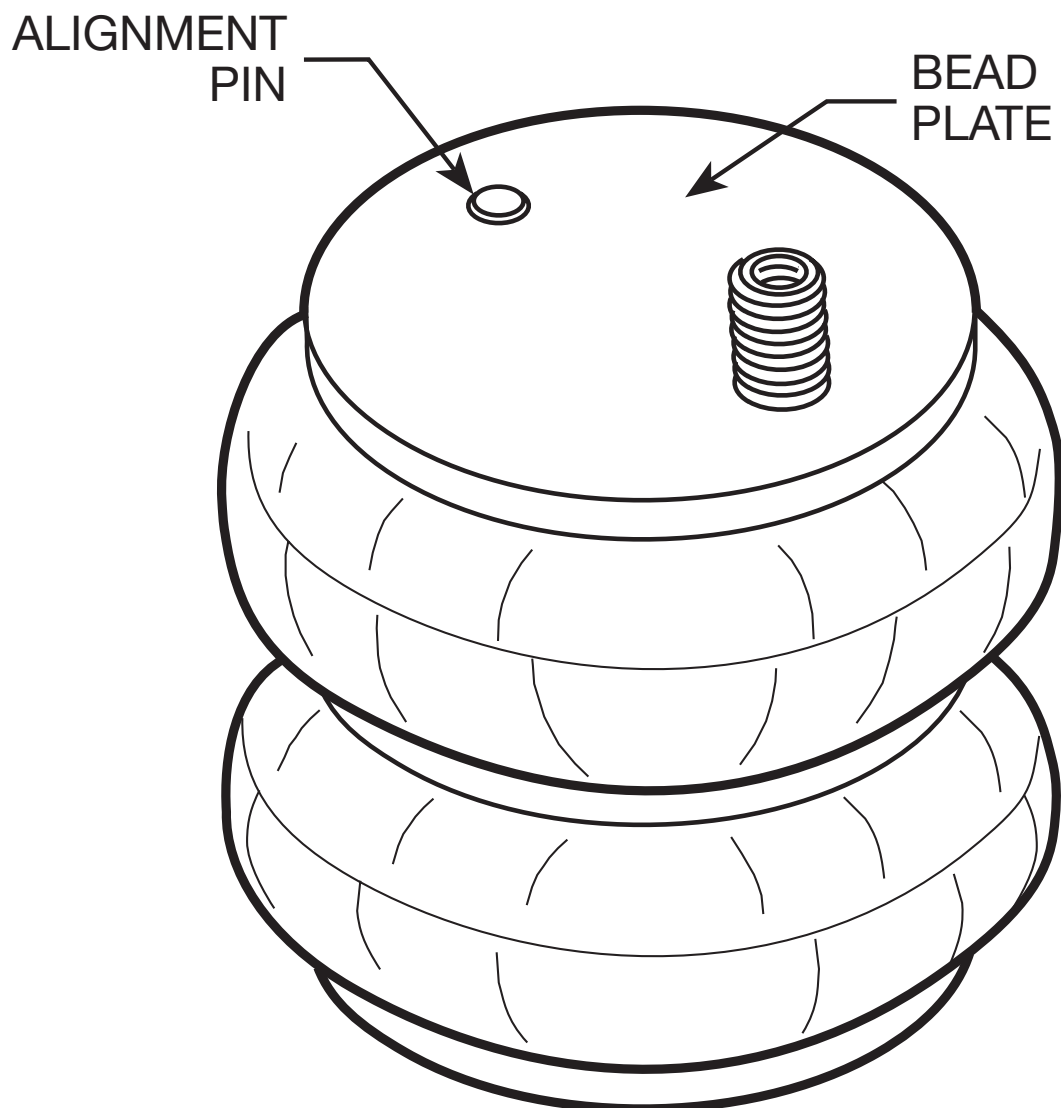

# No Drill Inflation Valve Bracket

## Parts List

Description	Part Number	Quantity
Inflation Valve Bracket	9483	1
Large Nylon Tie	9488	2

This bracket is designed to mount on receiver hitches round or square. Simply use the two provided large Nylon ties to affix the bracket to the receiver hitch tube. Install the air inflation valves on the bracket using two 5/16" flat washers per valve as supports. Then push the end of each air line tubing into the inflation valve as far as possible.

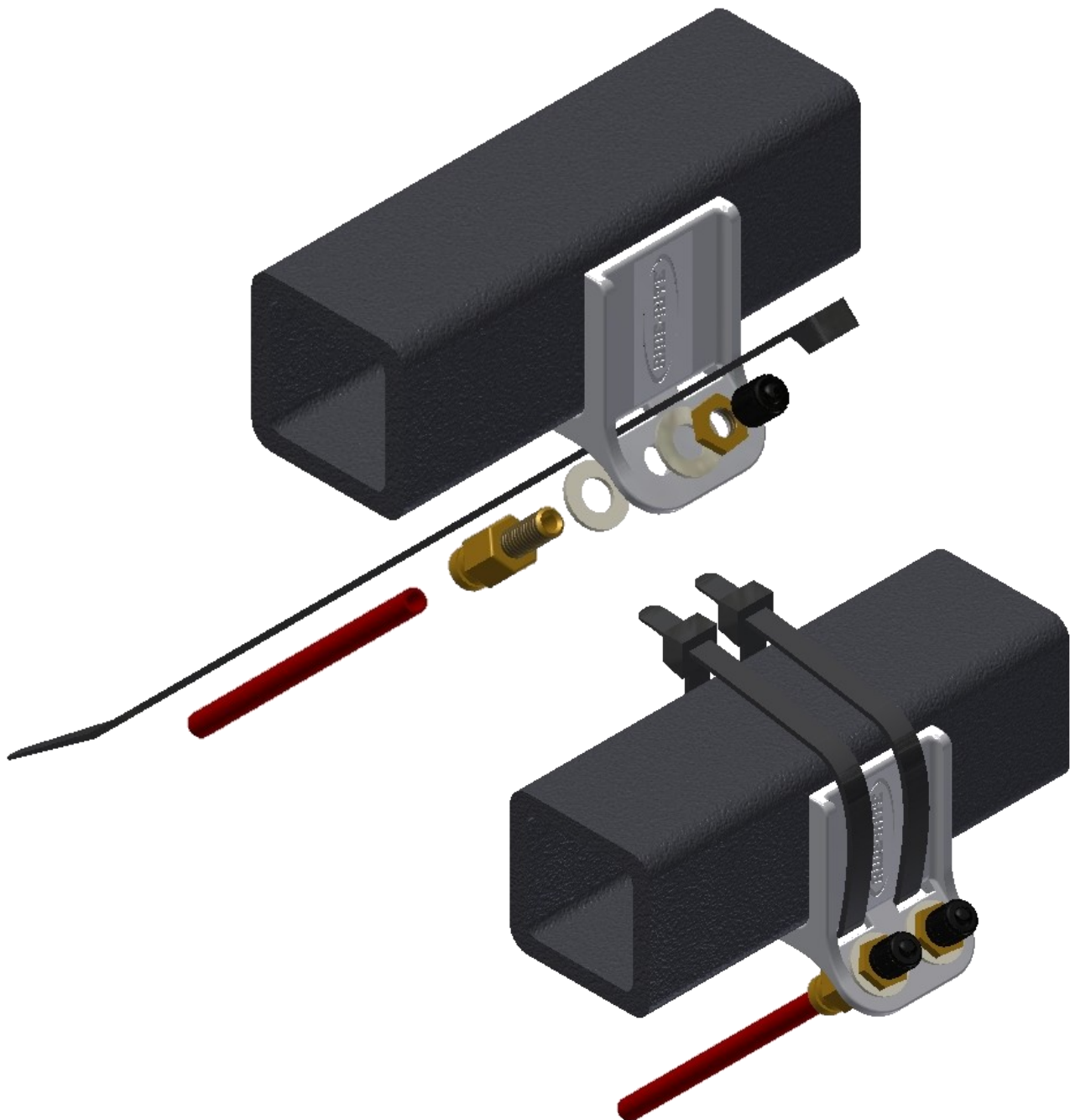

# Firestone

**World's Number 1  
Air Spring.**



FIRESTONE INDUSTRIAL PRODUCTS COMPANY



## Operating Instructions and Trouble Shooting Guide

---

Thank you for purchasing Firestone air helper springs. You have purchased a quality product from the world's number one air spring manufacturer.

This guide will provide answers to some of your questions regarding the use and operation of your new air helper springs. Following the guidelines in this manual will help provide you with many years of trouble-free service from your Firestone air helper springs.

For vehicle applications, air pressure requirements, air compressor CFM, maintenance, or air spring technical data, contact us at:

**[www.ride-rite.com](http://www.ride-rite.com)  
1-800-888-0650**

**INSTALLER: Please leave this manual with the vehicle's owner.**

### **WARRANTY QUESTIONS**

Go to **[www.riderite.com/installation-support](http://www.riderite.com/installation-support)**  
Select "Warranty Info" tab

## **SAFETY TIPS**

### **Never exceed the manufacturer's recommended Gross Vehicle Weight Rating (GVWR)**

As with your vehicle's tires, an air helper spring is a pneumatic device that supports a portion of the vehicle's weight. The air helper spring may fail as a result of punctures, impact damage, improper inflation, improper installation, or improper usage. To reduce the risk of failure, we strongly recommend the following:

**Never overload your vehicle.** The manufacturer's gross vehicle weight rating (GVWR) is stated on the specification plate on the chassis. You should weigh your vehicle on a truck scale when it is fully loaded and in a level condition to determine if you are exceeding the manufacturer's recommended GVWR.

Inspect the inflated air springs to verify that they do not contact any component of the vehicle under normal suspension operation. The air helper spring must flex and expand during normal operation. There must be at least 1/2" of clearance between the inflated air spring and any other component of the vehicle under normal suspension operation.

The kit is designed to clear all chassis components. If there is **any** interference, please call Firestone at 1 (800) 888-0650.

Inspect the air line tubing and the air spring to verify that they have not been too close to the exhaust system. If the distance between any portion of the air spring or air line tubing and the exhaust system is less than 6", a heat shield should be used.

Never inflate the air helper springs beyond the maximum pressure indicated in the installation manual.

Never attempt to remove any component of the air spring assembly when the air springs are inflated.

If an air helper spring has failed while you are on the road, operate your vehicle at reduced speeds. High speed over rough roads will result in severe bottoming of the air spring and may damage other vehicle components.

Never attempt to drive the vehicle in an unlevelled condition. Failure to level a heavily loaded vehicle may result in excessive body roll and possible damage or injury.

If unidentifiable problems exist with your air helper spring kit, visit Firestone on the web at [www.riderite.com](http://www.riderite.com) or call 1 (800) 888-0650 for technical assistance.

Never cut, weld, or modify the air helper springs or brackets.

Do not use aerosol tire repair products in the air helper springs or a tire patch of any kind on the air helper spring. If there is a hole in the air spring it must be replaced.

## **GENERAL INFORMATION**

Firestone air helper springs are heavy duty, quality air springs designed to supplement your vehicle's existing suspension system. These durable air springs allow you to maximize your vehicle's load carrying capacity through the use of air pressure. Proper installation, use, and operation will provide the maximum service life and performance your air spring kit is capable of delivering. These instructions will help you obtain the maximum benefits available from your air spring kit.

### **RIDE-RITE™ AIR HELPER SPRINGS**

Ride-Rite™ air helper springs are installed between the frame and the suspension of trucks, vans, and motorhomes. Ride-Rite™ air helper springs are capable of supporting loads up to 5000 lbs per pair.\*

### **SPORT-RITE™ AIR HELPER SPRINGS**

Sport-Rite™ air helper springs are installed between the frame and suspension of light trucks, and utilize a sleeve-style air spring to enhance the ride when the vehicle is loaded or unloaded. Sport-Rite™ air helper springs are capable of supporting loads up to 3000 lbs per pair.\*

### **LEVEL-RITE™ AIR HELPER SPRINGS**

Level-Rite™ air helper springs replace the existing shock absorber with a fully-protected, reversible sleeve air spring paired it with a high-performance Bilstein monotube shock absorber for perfectly matched performance characteristics over the entire operation spectrum. Level-Rite™ air helper springs are capable of supporting loads up to 1000 lbs per pair.\*

## **BASIC OPERATION**

As your vehicle is loaded, the stock suspension is compressed under the weight of the load. Your vehicle's stock suspension system has been designed so that it will provide optimum performance and handling with a specific load on the vehicle. When your vehicle is loaded, its performance, handling characteristics, and ride quality may be compromised. As the stock suspension is compressed, the ride may become "mushy", and you may encounter sway and handling problems. As weight is added to the vehicle, the air helper springs become an active part of

\*Do not exceed the vehicle's recommended gross vehicle weight rating (GVWR)

the suspension system. As more air pressure is added to the air springs, they will support more weight. You will be able to compensate for a heavy load by adding air pressure to the air springs, thereby reducing sway and handling problems associated with a heavily loaded vehicle.

<b>TABLE "A"</b>	
<b>ALL TORQUE SPECIFICATIONS</b>	
Using a torque wrench, torque the threaded fasteners to the following specifications:	
Fasteners used on studs and blind holes in air springs	15 – 20 ft lbs
Hex nuts installed on carriage bolts	10 – 15 ft lbs
Hex nuts installed on 3/8" hex bolts	28 – 32 ft lbs
Hex nuts and bolts used to secure brackets to frame	28 – 32 ft lbs
Hex nuts installed on U-bolts	15 – 20 ft lbs
Hex bolts securing tapered sleeve style air spring to lower bracket	10 – 12 ft lbs

### **PREVAILING-TORQUE LOCK NUTS**

In order to assure trouble-free operation, your air spring kit includes a variety of self-locking threaded fasteners. Your kit may include prevailing-torque lock nuts. Prevailing-torque lock nuts may be more difficult to install, but will not come loose under normal suspension operation.

### **THREAD LOCKING COMPOUND**

The hex bolts used to secure the air spring to the brackets may have a locking compound applied to the threads. Lock washers are not required when using a fastener with pre-applied thread locking compound. When installing fasteners with thread locking compound, follow the torque recommendations listed in table.

### **HELICAL LOCK WASHERS**

Your air helper spring kit may include helical lock washers. In order to properly use the lock washer, tighten the nut/bolt fastener just enough to flatten the lock washer. Overtightening the fastener may damage the nut or bolt. When using helical lock washers, follow the torque recommendations listed in Table "A".

### **AIR FITTINGS**

Your kit will include one of two types of push-to-connect air fittings: fittings with a thread locking compound pre-applied to the threads or fittings with a Nylon collar in place of the thread locking compound.

The pre-applied thread sealant, thread the air fitting into the air spring and tighten the fitting securely to engage the pre-applied thread sealant.

The Nylon collar, thread the air fitting into the threaded hole on the air spring so that the Nylon collar makes contact with the top of the air spring and then tighten 1/2 turn. No thread sealant is required.

Both types of air fittings allow easy connection between the air fitting and the air line tubing. To install the air line in the fittings, cut the tubing as square as possible using a sharp utility knife or razor blade. Push the air line into the fitting as far as possible. If the tubing must be removed from the fitting, first release the air pressure from the air spring. Push the collar towards the body of the fitting and then pull the tubing out.

### **PRESSURE DIFFERENTIAL BETWEEN AIR SPRINGS**

It is not uncommon to have different pressures between the air springs after the vehicle has been brought to a level condition. If the vehicle is within the manufacturer's recommended gross vehicle weight and you have not achieved a level condition after inflating the air springs to 100 psi, there may be a problem with your stock suspension. The leaf springs may have become fatigued over time or a leaf spring may be fractured. There may be an obstruction in the air system, not allowing the air pressure to reach the air helper springs.

### **AIR SPRING ALIGNMENT AND HEIGHT**

Upon completion of the installation, the air springs should be inspected for proper alignment. Although the air helper springs can function with some misalignment, it is preferred that the air springs be mounted so that they are aligned with as little top to bottom offset as possible.

Check the distance between the upper bracket and lower bracket (design height). The dimensions shown on **Page 5** are a guide to assist in determining the ideal operating height for your air helper springs.

## **INFLATING THE AIR SPRINGS**

With the air helper springs installed on your vehicle and the vehicle sitting on a level surface, visually verify that the vehicle is in a level state. If the vehicle is not level (front-to-back or from side-to-side) it can be brought to a level position by inflating the air springs. Each air spring has a separate inflation valve. To level the vehicle from front-to-back, add air pressure to both air springs in equal amounts. To level the vehicle from side-to-side, add more air pressure to the air spring on the lower side of the vehicle. When inflating the air springs, add air pressure in small quantities, checking the pressure frequently. The air spring requires much less air volume than a tire, and therefore, will inflate and deflate quickly.

**WARNING:** DO NOT EXCEED THE MAXIMUM PRESSURE AS INDICATED IN THE INSTALLATION MANUAL

## **LEVELING THE VEHICLE**

Check the level of your vehicle visually. If it is not level, either from front to back or from side to side, level it by inflating your air springs. (If your vehicle is equipped with a cab control unit or automatic control system refer to the directions for that device.) There is one inflation valve for each air spring. To level from front to back, add air pressure to both air springs equally. For side to side, add air pressure to the air springs on the side of the vehicle that is low. When adding air pressure to the air springs, remember that they have a much smaller volume of air than a tire so they will inflate much quicker. Add air pressure in short bursts until the vehicle is level. (NEVER EXCEED 100psi IN EACH AIR SPRING.)

## **MAINTENANCE**

It is considered normal for air helper springs to lose some air pressure over time. Normal pressure loss should not exceed 3 – 4 psi per week when the air springs are inflated to 50 psi. If the pressure loss is greater than 3 – 4 psi per week, there may be a leak in the system. Each time you check the pressure in the air springs, you will lose 1 – 3 psi. The air pressure should be checked at regular intervals.

It is recommended that the air pressure be checked according to the following guidelines:

At least monthly intervals during the continuous operation of the vehicle (see above)

When the vehicle is removed from long-term storage

If the air springs are used to assist in leveling an RV or camper on uneven ground, ensure that the vehicle is returned to a level ride height before departing.

The brackets used to secure the air helper spring to the vehicle should be inspected periodically for damage and for loose fasteners. Ensure that the air line tubing is clear of any sharp edges and routed away from the exhaust system. The brackets and air line tubing should be inspected every 6 months. Ensure that the threaded fasteners are torqued to the specifications listed on **Page 3**.

Accumulated sand, gravel, or other road debris on the air springs or brackets should be rinsed away with a garden hose each time the vehicle is washed.

If it is necessary to lift the vehicle by the frame, first release the air pressure from the air springs. This will allow the air springs to extend to their maximum length without being damaged. The uninflated air springs are capable of supporting the weight of the axle when the vehicle is lifted by the frame. After servicing of the vehicle is complete, lower the vehicle to the ground and reinflate the air helper springs to the desired pressure. **NOTE:** On Sport-Rite kits the air helper springs must be aired up to 50 psi and then release the air until the air helper springs are to the desired pressure.

## **ONLINE AUCTION PURCHASES**

Firestone will not replace missing components from any kit purchased through an online auction.

## AIR SPRING TECHNICAL DATA

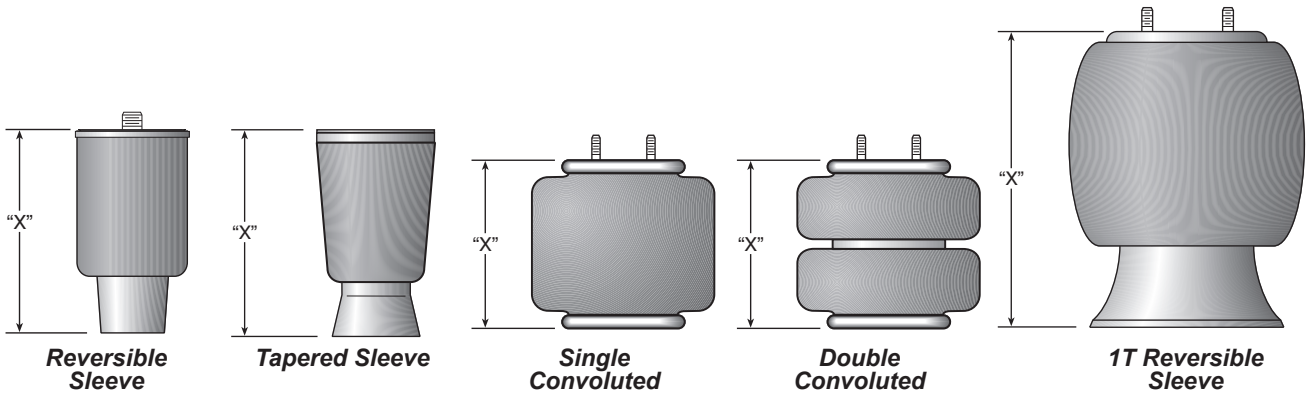





Part Number	Description	Style	"X" Ride Height	Min/Max Air Pressure	Max Load @100 psi (per pair)
6868	Single Convoluted	160BY	5.0" - 6.0"	5 / 100 psi	3600 lbs
6762 6764 6766	Double Convoluted	268C	4.5" - 5.5"	5 / 100 psi	3200 lbs
6397 6410 6781	Double Convoluted	267C1.5	5.5" - 6.5"	5 / 100 psi	4800 lbs
6401 6873 6859	Double Convoluted	224C	5.5" - 7.0"	5 / 100 psi	5000 lbs
7689 7701	Double Convoluted	26C	7.0" - 8.0"	5 / 100 psi	5640 lbs
7076	Reversible Sleeve	70mm	6.0" x 8.0"	10 / 100 psi	2000 lbs
9000	Tapered Sleeve	110/70 mm	7.75" - 8.75"	10 / 100 psi	3000 lbs
9001	Tapered Sleeve	110/70 mm	5.88" - 6.88"	10 / 100 psi	3000 lbs
9002	Tapered Sleeve	110/70 mm	6.75" - 7.75"	10 / 100 psi	3000 lbs
5405	1T Reversible Sleeve	1T14C-3	8.0" - 12.0"	5 / 100 psi	6400 lbs

This information is provided for reference purposes only. The bracketry and air springs in the Ride-Rite™ and Sport-Rite™ kits are designed to work with the original suspension and within the manufacture's Gross Vehicle Weight Rating (GVWR) for the intended vehicle. Brackets and air springs should not be interchanged or modified.

# Air Command™ Air Control Systems

Firestone has expanded the offering of Air-Rite™ Air Control Systems, which provides an instant air source for air suspension products. Adjust the ride for various load and road conditions with a flip of a switch or even a click on a remote. Individual air accessory components are also available, including compressors, air tanks and mounting solutions, providing a wide variety of air control assist solutions.

- Step 1** Choose the application you need; Single or Dual Leveling. »
- Step 2** Choose the style you want to control your air; Analog or Wireless. »
- Step 3** Choose the Duty Cycle needed for your kit/vehicle. Recommended duty cycle is listed in the Application Guide. »

<b>Light Duty</b>	<ul style="list-style-type: none"> <li>• 1-Year Warranty</li> <li>• Includes 9377 Compressor</li> <li>• Best for passenger cars, SUVs, vans, small pickups for occasional use and light loads</li> </ul>			
<b>Standard Duty</b>	<ul style="list-style-type: none"> <li>• 1-Year Warranty</li> <li>• Includes 9284 Compressor</li> <li>• Best for moderate usage, including towing boats, trailers 20' or smaller and medium loads</li> </ul>			
<b>Heavy Duty</b>	<ul style="list-style-type: none"> <li>• 2-Year Warranty</li> <li>• Includes 9499 Compressor</li> <li>• Best for 8-lug trucks, trailers larger than 20', slide-in campers and heavy loads</li> </ul>			
<b>Xtra</b>	<ul style="list-style-type: none"> <li>• 2-Year Warranty</li> <li>• Includes 9499 Compressor</li> <li>• Includes Half-Gallon Air Tank</li> <li>• Includes 9006 Air Hose</li> <li>• Best usage same as Heavy Duty, plus motorcycle tire, golf cart tire or trailer tire inflation</li> </ul>			
<b>Xtreme</b>	<ul style="list-style-type: none"> <li>• 2-Year Warranty</li> <li>• Includes 9287 Compressor</li> <li>• Includes 2-Gallon Air Tank</li> <li>• Includes 2311 Air Hose</li> <li>• Best usage same as Heavy Duty, plus off-road tire or truck tire inflation</li> </ul>			



## Single Leveling System

Equal pressure to the springs on both sides. This applies to most towables using a hitch.



**Analog**

**2538**

Mounting Plate: **2497**

**2158**

Mounting Plate: **2497**

**2097**

Mounting Plate: **2497**

**2266**

Mounting Plate: **2530**

**2543**

Mounting Plate: **2530**

## Dual Leveling System

Allows for side-to-side or front-to-back leveling. This applies to work trucks, in-bed campers and off-center loads.



**Analog**



**Wireless**

N/A

**2581**

Mounting Plate: **2588**

**2178**

Mounting Plate: **2497**

**2589**

Mounting Plate: **2588**

**2219**

Mounting Plate: **2497**

**2590**

Mounting Plate: **2588**

**2168**

Mounting Plate: **2530**

**2591**

Mounting Plates: **2588/2496**

**2549**

Mounting Plate: **2530**

**2592**

Mounting Plates: **2588/2496**

# TROUBLE SHOOTING GUIDE

## ***Air spring will not inflate***

Ensure that the air line tubing is inserted into the air fittings as far as possible. The tubing should go in the fitting 3/4 of an inch. You will feel some resistance when the tubing goes past the o-ring.

Clear any dirt or debris from inside the inflation valves.

Inspect the entire length of air line tubing to ensure that it is not kinked, damaged from exhaust heat, or cut due to contact with sharp edges

## ***Air spring will not hold air***

Normal pressure loss is no more than 3 - 4 psi per week when the air spring is inflated to 50 psi.

Using the inflation valve cap as a core tool, ensure that the valve stem core is installed securely.

Apply a solution of soap and water to the air fittings, air line, and air springs to check for leaks. Tighten the air fitting or re-install the tubing in the air fitting to stop the leak. Rinse the soap and water solution from the system when complete.

If a leak can not be detected with the soap and water solution, deflate the air springs and remove them from the vehicle. Re-install the tubing and inflation valve on the air spring and inflate the air spring to a maximum of 20 psi. Submerge the air spring in a bucket of water to check for leaks.

## ***Locations of air leaks***

Leaks occur most often at the threaded connection between the air fittings and the air springs. Tighten the fitting to engage the pre-applied orange thread sealant or until the nylon collar makes contact with the air spring, plus 1/2 turn, depending on which type of fitting is included in your kit. (See air fittings on page 3)

The end of the air line tubing must be cut square and clean to avoid burrs in the connection to the air fittings. The push-to-connect fittings require a square cut to properly seal. The tubing can be removed from the fitting by first releasing the air pressure from the air spring. Push the collar on the fitting toward the body of the fitting. While holding the collar in, pull out the tubing. Cut the tubing squarely and push the tubing into the fitting as far as possible.

## ***The vehicle is not level***

Check for proper inflation of the air springs on each side of the vehicle.

Check for obstructions in the air system or vehicle components that may be restricting suspension travel.

### **IMPORTANT**

**NYLON TUBE CUTTING:**  
FOLLOW THESE INSTRUCTIONS  
TO AVOID LEAKS

