

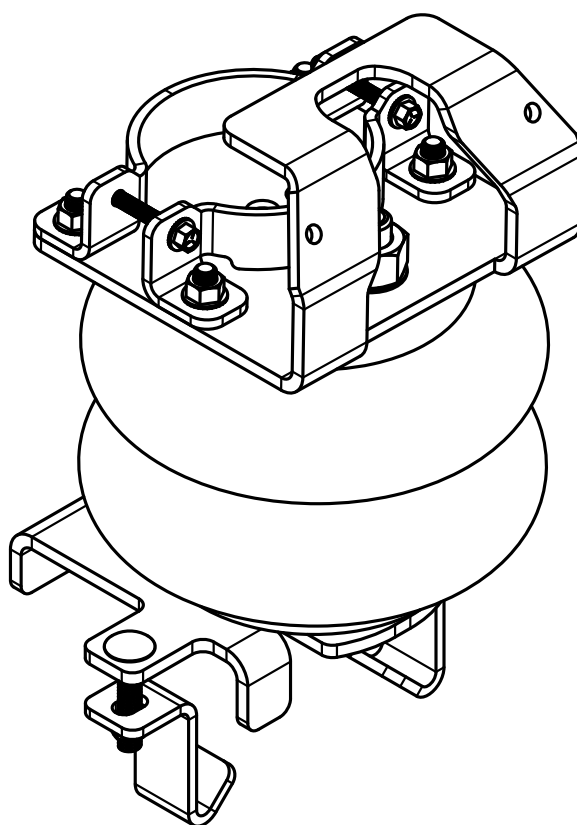

[riderite.com](http://riderite.com)

# INSTALLATION INSTRUCTIONS



**Firestone**

Firestone Industrial Products

# ! IMPORTANT

*PLEASE DON'T HURT YOURSELF, YOUR KIT OR YOUR VEHICLE. TAKE A MINUTE TO READ THIS IMPORTANT INFORMATION.*

DO NOT INSTALL IF THE TRUCK HAS BEEN LIFTED AND THE STOCK JOUNCE BUMPER SPACERS ARE NOT ON THE VEHICLE. *This kit is to be used on a **pickup truck only**, and **DOES NOT INCREASE YOUR VEHICLE'S MAXIMUM LOAD.***

## **SAFE INSTALLATION**

Please take all safety precautions during installation. A hydraulic jack can fail, and if that happens, you can be seriously hurt, or worse, if you are relying on it to hold up the vehicle. If you use a hydraulic jack, secure jack stands in the appropriate locations and chock any tires still touching the ground.

Wear safety glasses or goggles. Your eyes may be lower than some parts and pieces, and you don't want to lose an eye.

Remove the possibility of any electrical issues by disconnecting the negative battery cable.

## **KIT CLEARANCE**

There must be a minimum of 1/2" clearance around all installed components when the air springs are inflated and under a load. The air springs must flex and expand during operation, so the clearance keeps the kit from rubbing against parts of the vehicle.

## **VEHICLE GVWR**

NEVER exceed the maximum load recommended by the vehicle manufacturer (GVWR). The GVWR can be found in your vehicle's owner's manual or on the data plate on the driver's side door.

## **INFLATING THE AIR SPRINGS**

When inflating air springs, add air pressure in small quantities, checking air pressure frequently. The air springs have much less air volume than a tire, so they inflate much more quickly.

## **PRESSURE TO LOAD**

The air springs will support approximately 50 lbs. of load for each PSI of inflation pressure (per pair). For example, 50 PSI of inflation pressure will support a load of 2500 lbs. per pair of air springs.

## **APPROPRIATE AIR PRESSURE**

For best ride, use only enough air pressure in the air springs to level the vehicle when viewed from the side (front to rear). This will vary, depending on the load, location of the load, condition of the existing suspension, and personal preference.

## **OPTIONAL T-FITTING**

This kit includes inflation valves and air line tube for each air spring, allowing you to compensate for unbalanced loads. If you prefer a single inflation valve system to provide equal pressure to both air springs, your dealer can supply the optional "T" fitting (Part # 3025 or WRI-760-3461 retail pack).



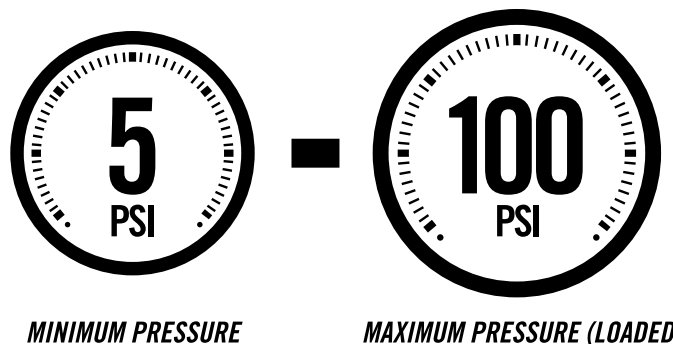

**ONCE INSTALLED SUCCESSFULLY, FOLLOW THESE PRESSURE REQUIREMENTS FOR THE AIR SPRINGS:**



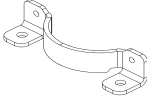
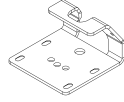
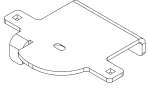

# PARTS

Compare the parts below to your kit. Ensure you have all pieces, and organize them for an easier installation.











## MAIN KIT CONTENTS

PT # 8401	 x2 AIR SPRING	PT # 5897	 x4 CLAMP SPRING MOUNT	PT # 5901	 x2 UPPER BRACKET
PT # 5902	 x2 LOWER BRACKET	PT # 5900	 x4 HOOK SPRING MOUNT	PT # 9153	 x1 AIR LINE TUBE (30 FEET)
PT # 1004	 x1 HEAT SHIELD				

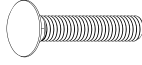
## A24-760-7560 INFLATION VALVE BRACKET KIT

PT # 9483	 x1 NO-DRILL INFLATION VALVE BRACKET	PT # 9488	 x2 LARGE NYLON TIE
-----------	-----------------------------------------------------------------------------------------------------------------------	-----------	-------------------------------------------------------------------------------------------------------

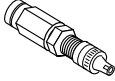
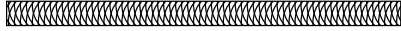
## A21-760-2709 HARDWARE PACK

PT # 3046	 x2 AIR FITTING	PT # 3064	 x2 INTERNAL TOOTH LOCK WASHER	PT # 3513	 x4 1/4" - 20 x 2" HEX SCREW
PT # 3295	 x2 3/4" - 16 HEX NUT	PT # 3510	 x4 1/4" - 20 FLANGE NUT	PT # 3401	 x4 3/8" - 16 x 2" CARRIAGE BOLT
PT # 3033	 x4 5/16" FLAT WASHER	PT # 3514	 x8 3/8" - 16 x 1" FLAT HEAD SCREW	PT # 9168	 x10 BLACK NYLON TIE
PT # 3022	 x12 3/8" - 16 FLANGE LOCK NUT	PT # 3032	 x2 INFLATION VALVE AND VALVE CAP ASSEMBLY	PT # 0899	 x2 THERMAL SLEEVE
PT # 3142	 x2 3/8" - 16 x .625" FLAT HEAD BOLT				

# CONTENTS AND OVERVIEW

PAGE 4 BUILD UPPER MOUNT ASSEMBLY & REMOVE EXISTING JOUNCE BUMPER

PAGE 5 INSTALL UPPER SPRING MOUNT ASSEMBLY

PAGE 6 DRY FIT AIR SPRING AND LOWER BRACKET

PAGE 7 SECURE LOWER BRACKET TO AIR SPRING

PAGE 8 INSTALL HOOK SPRING MOUNTS & SECURE AIR SPRING

PAGE 9 INSTALL THE HEAT SHIELD

PAGE 10 AIR LINE TUBE & INFLATION VALVE INSTALLATION

PAGE 11 INSTALL & ROUTE AIR LINE TUBE

PAGE 12 CHECKING THE SYSTEM

PAGE 13 FIXING AN AIR LEAK

PAGE 14 FINISHING THE INSTALLATION

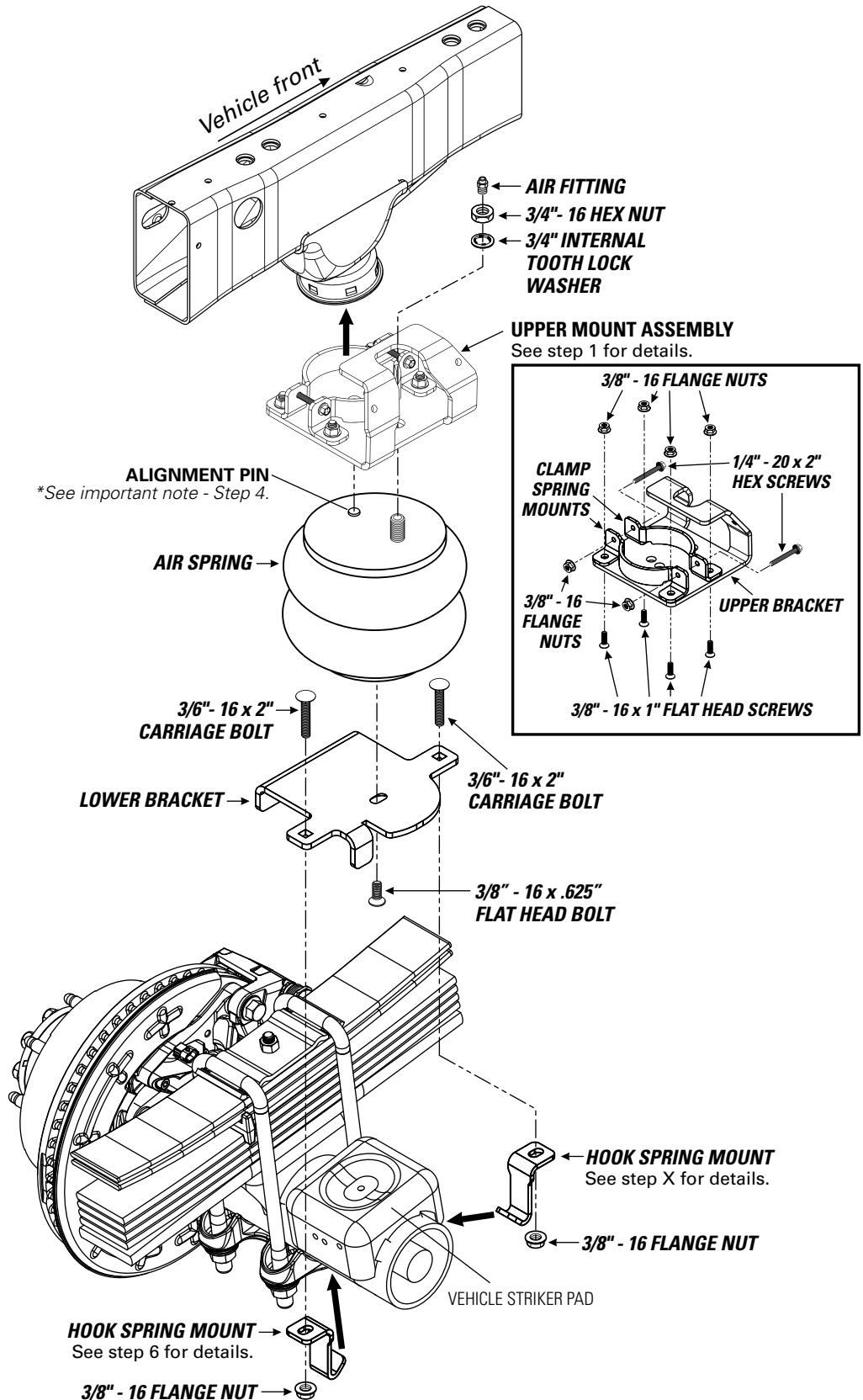

## BUILD UPPER MOUNT ASSEMBLY

# 1

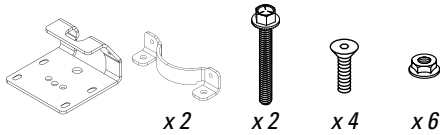

- Using the flat head screws and flange nuts, loosely bolt clamp spring mounts to the upper bracket, as shown. **DO NOT TIGHTEN AT THIS POINT.**



START THE INSTALLATION ON THE LEFT SIDE OF THE VEHICLE WHEN FACING FORWARD.

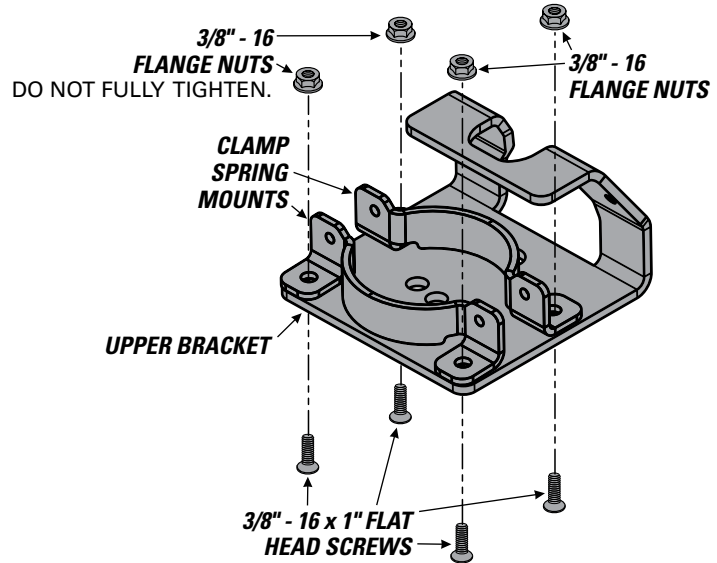

- Install the hex screws and flange nuts, as shown. **DO NOT TIGHTEN AT THIS POINT.**

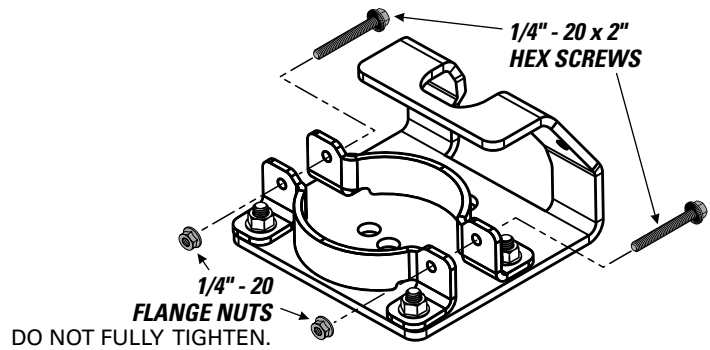

## REMOVE THE EXISTING JOUNCE BUMPER

# 2

- Use a pry bar or flat head screwdriver to pry out the existing jounce bumper.

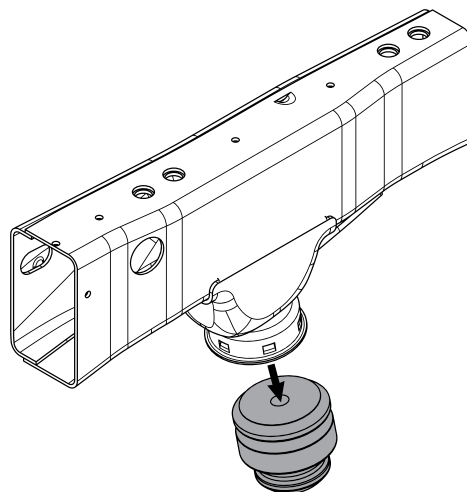

# 3

## INSTALL UPPER SPRING MOUNT ASSEMBLY TO JOUNCE BUMPER CUP

- 1 Using the upper mount assembly from step 1, slide clamps so that they are farthest apart and place over the jounce bumper cup.

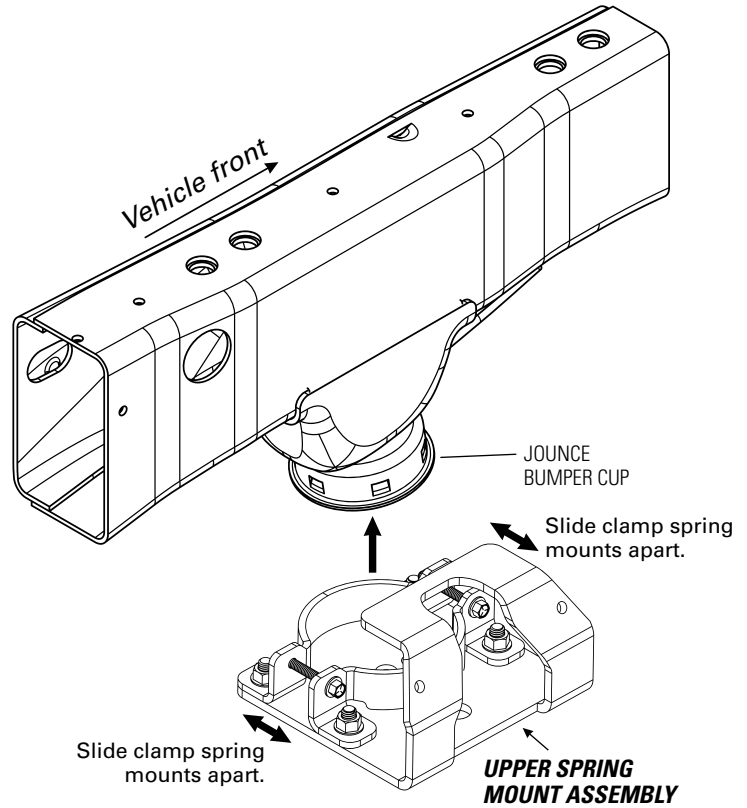

- 2 Press the upper mount assembly tight against the bottom of the jounce bumper cup, **assuring there is no gap.**

- 3 Slowly and evenly tighten hex screws and flange nuts on each side of clamp until the upper mount assembly is securely attached to jounce bumper cup.

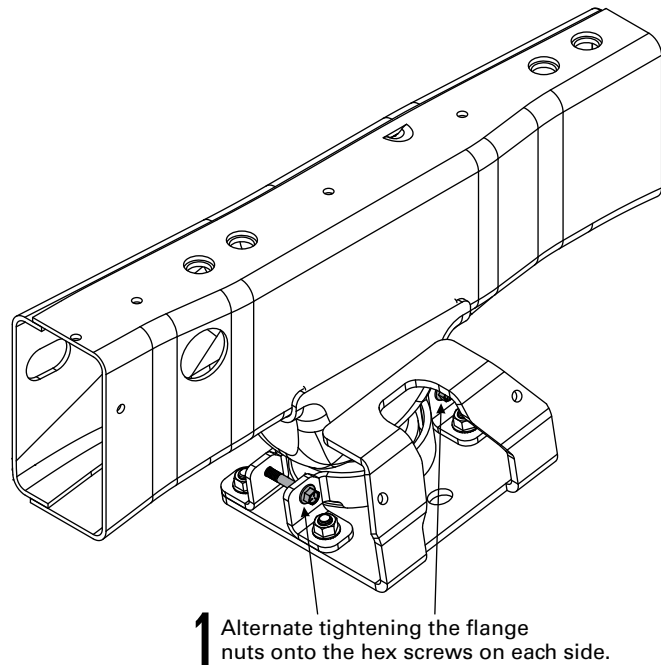

ASSURE THERE IS NO GAP BETWEEN THE TOP OF THE UPPER BRACKET AND THE BOTTOM OF THE JOUNCE BUMPER CUP.

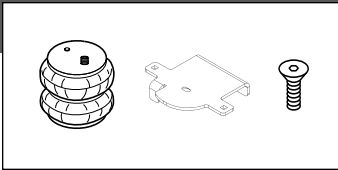

INSTALLING THE RIGHT SIDE? REMEMBER TO INSTALL THE HEAT SHIELD IN STEP 7 FIRST!

**1** Fasten the lower bracket to the air spring using the flat head bolt, as shown. **DO NOT FULLY TIGHTEN IN THIS STEP.**

**2** Dry fit into place, assuring the alignment pin is fully seated into the middle hole on the upper spring mount assembly.

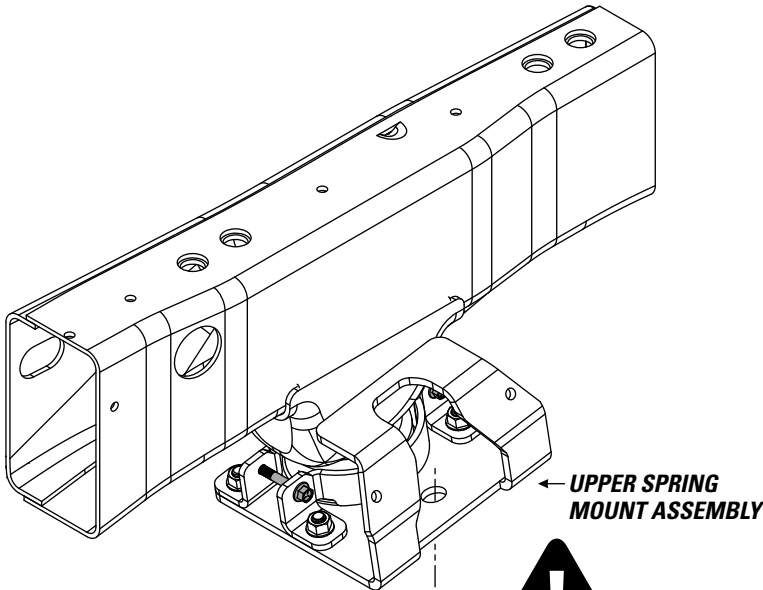

← UPPER SPRING MOUNT ASSEMBLY

**VIEW FROM BELOW**

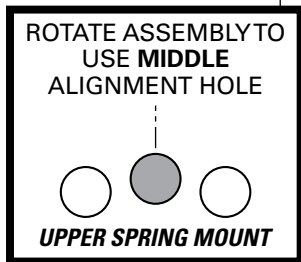

ALIGNMENT PIN ON AIR SPRINGS MUST BE INSTALLED TO FULLY SEAT INTO THE MIDDLE ALIGNMENT HOLE IN THE UPPER BRACKET. FAILURE TO DO SO WILL CAUSE IT TO BE PUSHED INTO THE BEAD PLATE, CREATING AN AIR LEAK, AND RESULTING IN AN AIR SPRING FAILURE THAT IS **NOT WARRANTABLE. THE ALIGNMENT PIN CANNOT HOLD 2,500 LBS! IT IS USED FOR ALIGNMENT ONLY!**

ALIGNMENT PIN

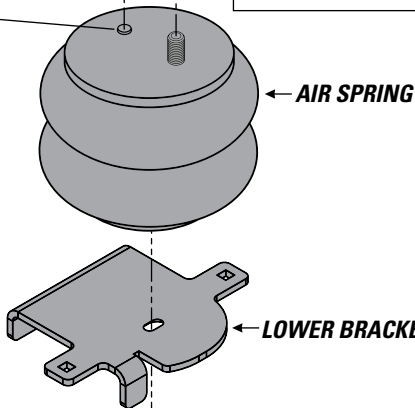

← 3/8" - 16 x .625" FLAT HEAD BOLT  
DO NOT FULLY TIGHTEN IN THIS STEP.

**1** Position the lower bracket so that it sits squarely on the jounce bumper striker pad.

**2** Assure that the alignment pin is fully seated in the middle hole, as noted in step 4.

**3** Make alignment marks, as shown.

**4** Remove air spring assembly.

**5** Assuring your marks are aligned, fully tighten the flat head bolt to secure the lower bracket to the air spring.

**6** Fit the air spring assembly back into position.

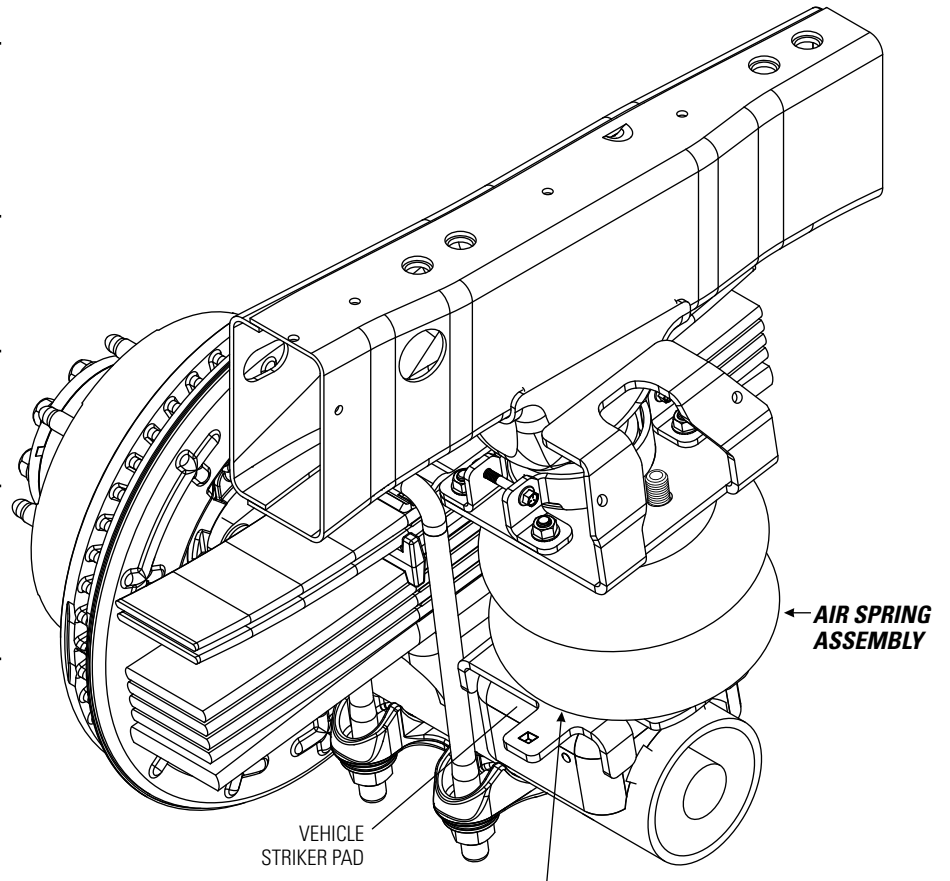

ALIGNMENT PIN ON AIR SPRINGS MUST BE INSTALLED TO FULLY SEAT INTO THE MIDDLE ALIGNMENT HOLE IN THE UPPER BRACKET. FAILURE TO DO SO WILL CAUSE IT TO BE PUSHED INTO THE BEAD PLATE, CREATING AN AIR LEAK, AND RESULTING IN AN AIR SPRING FAILURE THAT IS **NOT WARRANTABLE. THE ALIGNMENT PIN CANNOT HOLD 2,500 LBS! IT IS USED FOR ALIGNMENT ONLY!**

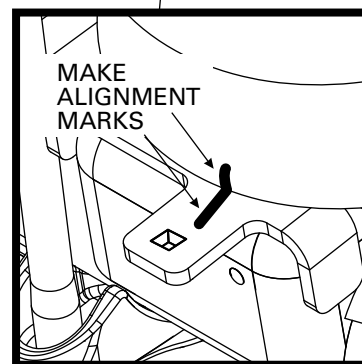



INSTALL HOOK SPRING MOUNTS & SECURE AIR SPRING

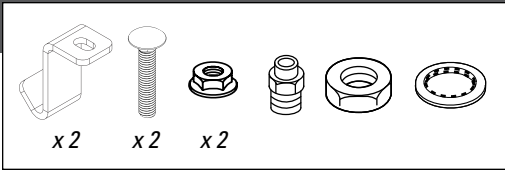

**1** Assure that the alignment pin is fully seated in the middle hole, as noted in step 4.

**2** Fasten the air spring to the upper spring mount assembly, as shown.

**3** Install the hook spring mounts, as shown. Assure that the mount hooks under the edge of the striker pad.

**4** Slowly and evenly tighten the nut on each carriage bolt until lower bracket is secure.

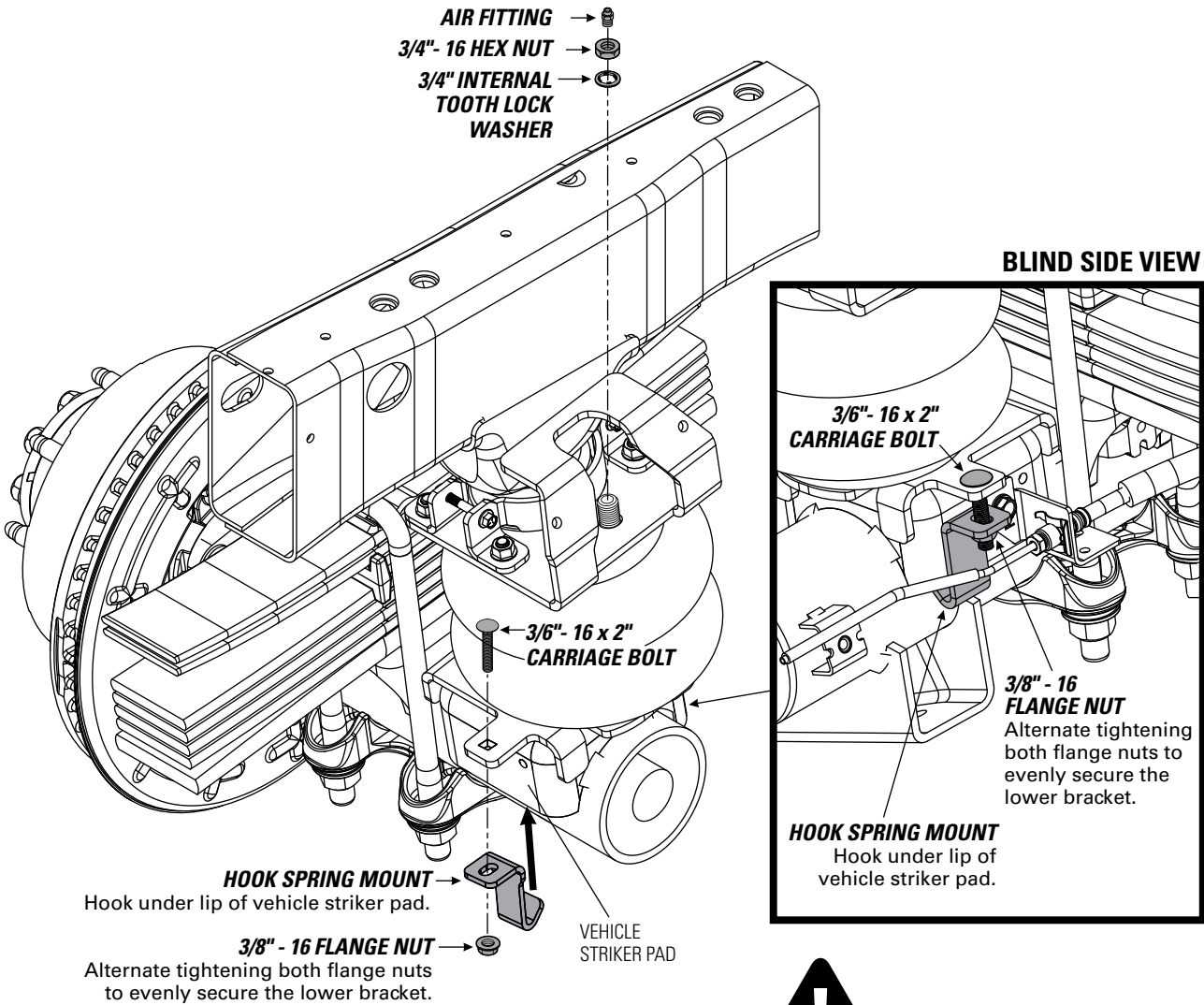

USE YOUR HAND TO CHECK FOR THE PROPER CLEARANCE AROUND THE AIR SPRING. IF YOUR HAND DOES NOT FIT BETWEEN THE AIR SPRING AND OTHER COMPONENTS, IT WILL RUB!

# 7

## INSTALL THE HEAT SHIELD

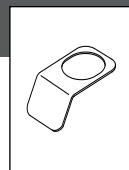

- 1 Secure the heat shield by clamping it between the air spring and upper spring mount assembly.

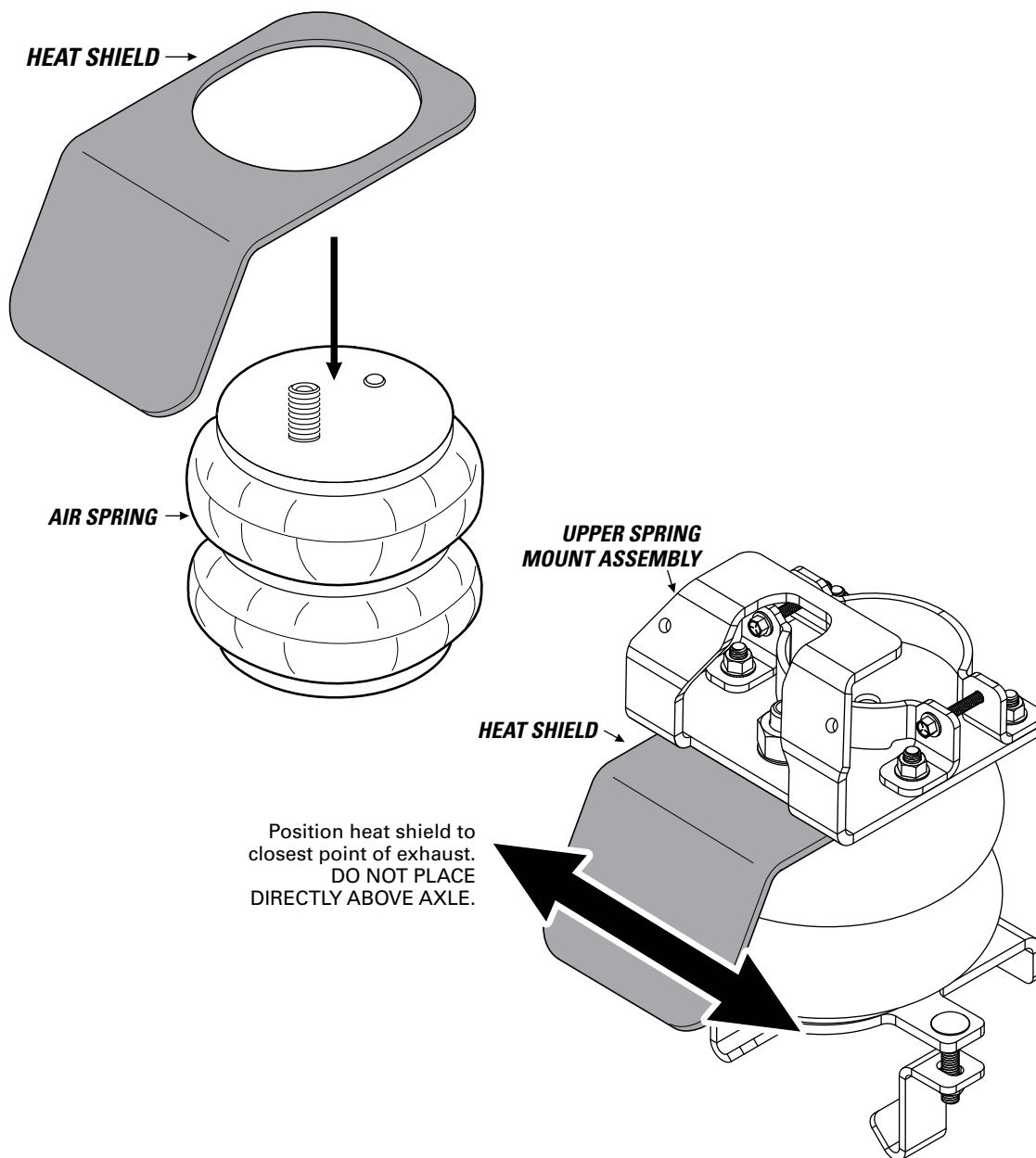

**AWESOME!** You're done with the left side. Go back to step 1 and repeat the steps for the right side installation.

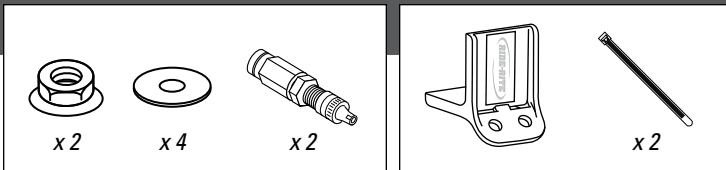

IF USING THE OPTIONAL NO-DRILL INFLATION VALVE BRACKET, CHOOSE OPTION 1. IF DRILLING, CHOOSE OPTION 2. **INFLATION VALVES MUST BE ACCESSIBLE BY AN AIR CHUCK.**

**1** Secure the air inflation valve bracket to a protected, secure location. **PROCEED TO STEP 3.**

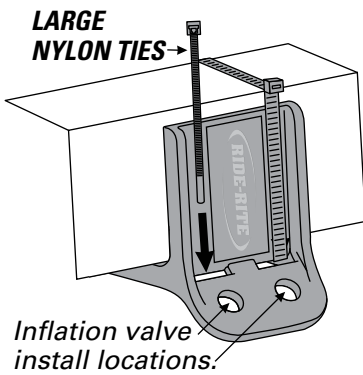

**2** Select a protected location to install the inflation valves, such as the bumper or the body of the vehicle.

Drill two 5/16" holes for Inflation Valve install locations.

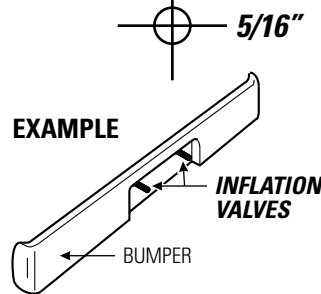

**3** Install inflation valve assembly as shown.

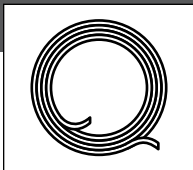
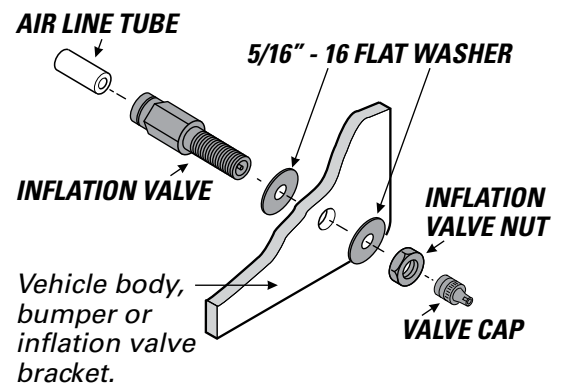

**1** Match air line tube ends.

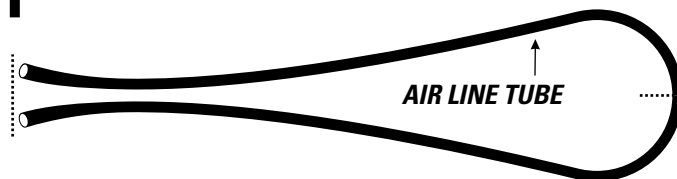

**2** Find center of air line tube, make a square cut with tube cutter or sharp utility knife.

**DO**

Make sure the cut is as square as possible. Use a tube cutter or sharp utility knife.

**DON'T**

Fold or kink the air line tube. Cut the air line tube at an angle. Use pliers, scissors, snips, saws, or side cutters.

**PROPER AND IMPROPER CUTS IN THE AIR LINE TUBE**

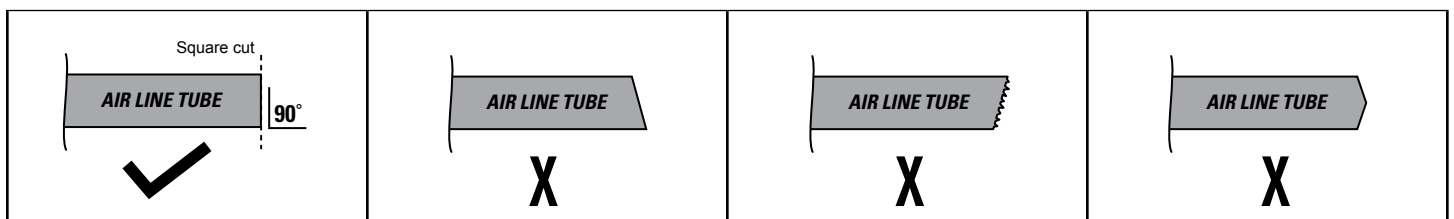

# 10

## INSTALLING AIR LINE TUBE INTO AIR FITTINGS AND INFLATION VALVE

**1** Insert end of air line tube into air fitting.

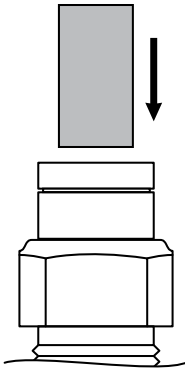

**2** Push air line tube into air fitting as far as possible.

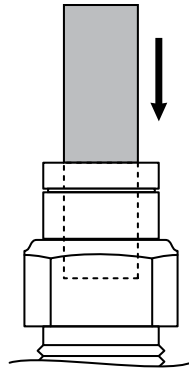

**3** Gently pull on the air line tube to check for a secure fit.

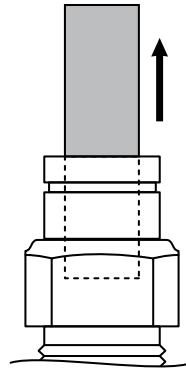

**4** To remove, push down collar and gently pull air line tube away.

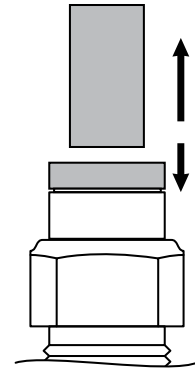

**Removal Tip:** Use a 1/4", 5/16", or 6mm open-ended wrench to push the collar down.

# 11

## ROUTE AND SECURE AIR LINE TUBES

Air line tube routes will vary, depending on your truck, and requires you to choose the best path from the air springs to the inflation valves. Use the instructions below to help you choose.

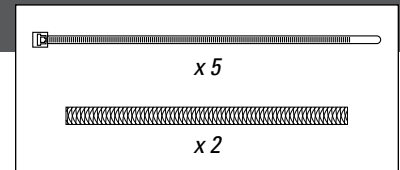

# DO

Select routes protected from heat, debris, and sharp edges. Use thermal shields near heat sources. Use Nylon ties to secure the air line tube.

# DON'T

Bend or sharply curve air line tubes. Leave air line tube exposed to sharp edges. Use unnecessary lengths of air line tube. Route air line tube near moving parts. Let air line tube hang unsecured from vehicle. Scar air line tube while routing.

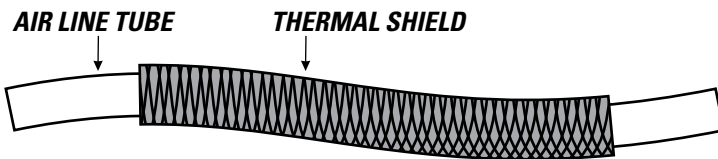

USE SUPPLIED THERMAL SHIELDS WHEN AIR LINE TUBE RUNS **WITHIN 6 INCHES** OF HEAT SOURCES.

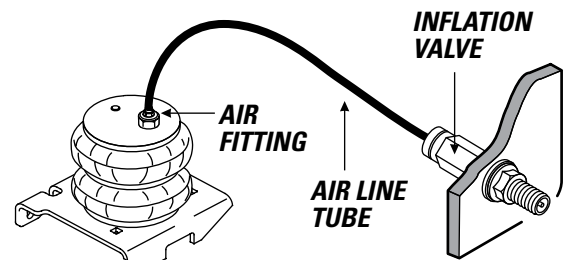

- 1** Place an air chuck onto the inflation valve and fill the system to **70 PSI**.

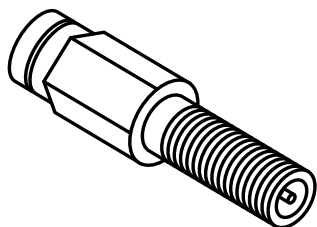

AIR SPRINGS INFLATE QUICKLY. CHECK AIR PRESSURE WHILE INFLATING.

- 2** Spray fittings with soap and water mixture.



- 3** Observe bubbles.

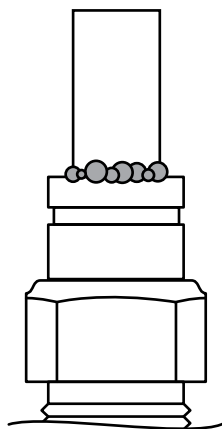

**SMALL SOAP BUBBLES  
THAT DO NOT EXPAND**

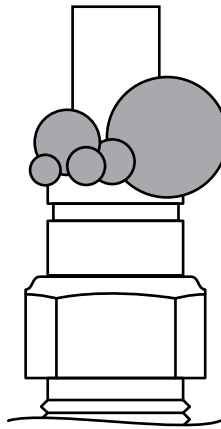

**SOAP BUBBLES  
THAT EXPAND**



# NO LEAKS?

Congratulations! Continue to step 14 to finish installation. Review the Operating Instructions.

# LEAK?

Bummer. Continue to step 13 to fix the leak.

- 1** Press the air valve on end of inflation valve to release all air pressure.

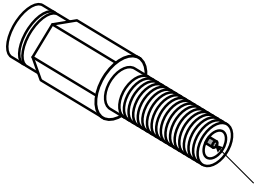

AIR VALVE



EXHAUST ALL AIR FROM THE SYSTEM PRIOR TO RELEASING AIR LINE TUBES FROM AIR FITTINGS.

#### LEAK AT AIR LINE TUBE AND AIR FITTING

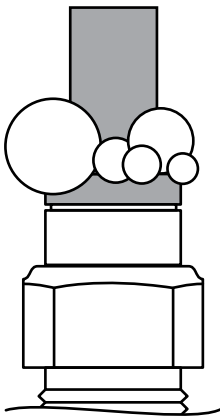

Release air line tube (see page 11). Review proper cuts and procedures in step 9. Repeat steps 10 and 12.

#### LEAK AT BASE OF AIR FITTING ON AIR SPRING

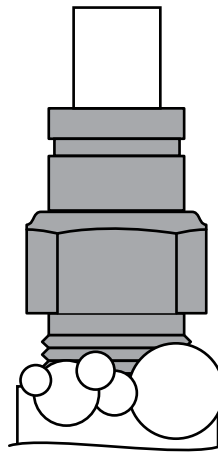

Tighten air fitting one turn or until leak stops.

#### LEAK OUT OF THE VALVE CORE ON INFLATION VALVE

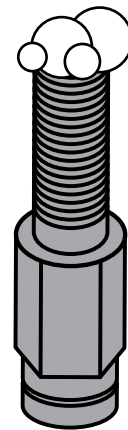

Tighten valve core with valve core wrench on inflation valve cap.

# STILL HAVE A LEAK?

Refer to the Troubleshooting section of the Instruction Manual.

**SAFELY RETURN VEHICLE TO OPERATIVE STATE**

If you removed any wheels during installation, install the wheels and torque the lug nuts to the manufacturer's specifications.

Safely remove any jack stands and wheel chocks used during installation.

Re-attach the negative battery cable.

**DOUBLE-CHECK AIR SPRING CLEARANCE**

Check the air springs once again for the proper 1/2" minimum clearance. Perform clearance check again when vehicle is under load.

**VEHICLE GVWR**

NEVER exceed the maximum load recommended by the vehicle manufacturer (GVWR). The GVWR can be found in your vehicle's owner's manual or on the data plate on the driver's side door. Consult your local dealership for additional GVWR specifications.

**READ AND UNDERSTAND THE OPERATING INSTRUCTIONS**

The Ride-Rite system can improve handling and comfort. Take the time to learn how to properly use and maintain your investment by reading the Operating Instructions.



USE YOUR HAND TO CHECK FOR THE PROPER CLEARANCE AROUND THE AIR SPRING. IF YOUR HAND DOES NOT FIT BETWEEN THE AIR SPRING AND OTHER COMPONENTS, IT WILL RUB!

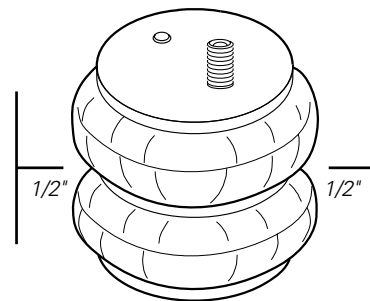

# ! IMPORTANT

**A MINIMUM OF 5 PSI MUST BE MAINTAINED IN THE AIR SPRINGS AT ALL TIMES**

Too much air pressure in the air springs will result in a firmer ride, while too little air pressure will allow the air springs to bottom out over rough conditions, and will not provide the improvement in handling that is possible.



MINIMUM PRESSURE



MAXIMUM PRESSURE (LOADED)



[riderite.com](http://riderite.com)

## BEFORE YOU DRIVE, CONFIRM THE FOLLOWING:

- Do you have a minimum of 5PSI in your air springs?
- Are your air springs standing 5 1/2" - 6 1/2" tall?
- Are your air springs properly aligned, left-to-right and front-to-back?
- Are your nuts and bolts tight?
- Put your paper work back into the sleeve and keep it in your glove compartment for future reference.
- You've been bagged...and now your suspension is Airide™ equipped! Show it off with the supplied decal!

5 1/2" - 6 1/2"

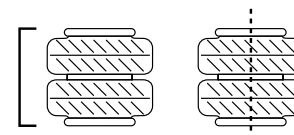

## NEED INSTALLATION HELP?

Email us at [rrtech@fsip.com](mailto:rrtech@fsip.com). Please include photos to help us better diagnose and understand any problems you may be experiencing.

# Firestone

Firestone Industrial Products

CONNECT WITH US



FirestoneIP



Firestone Ride-Rite